

ΑΝΤΙΓΟΝΑ ΚΑΙ ΑΝΤΙΓΟΝΟΠΑΡΟΥΣΙΑΣΗ

Περικλής Γ. Φούκας
B' Εργαστήριο Παθολογικής Ανατομικής
Ιατρικής Σχολής, ΕΚΠΑ
Π.Γ.Ν. Αττικόν

Ανοσία / Immunity (άνευ νόσου): είναι η προστασία (άμυνα) του οργανισμού έναντι βλαπτικών παραγόντων κυρίως μικροοργανισμών, η οποία επιτυγχάνεται μέσω του ανοσοποιητικού / ανοσολογικού συστήματος (αμυντικό σύστημα)

Ανοσιακή απάντηση / Immune response : είναι η συλλογική και συντονισμένη απάντηση του οργανισμού στην εισαγωγή ξένων ουσιών που επιτυγχάνεται μέσω των κυττάρων και των μορίων του ανοσιακού συστήματος

Ανοσιακή απάντηση

Μη ειδική, έμφυτη (Innate)

Ειδική, προσαρμοστική (Adaptive)

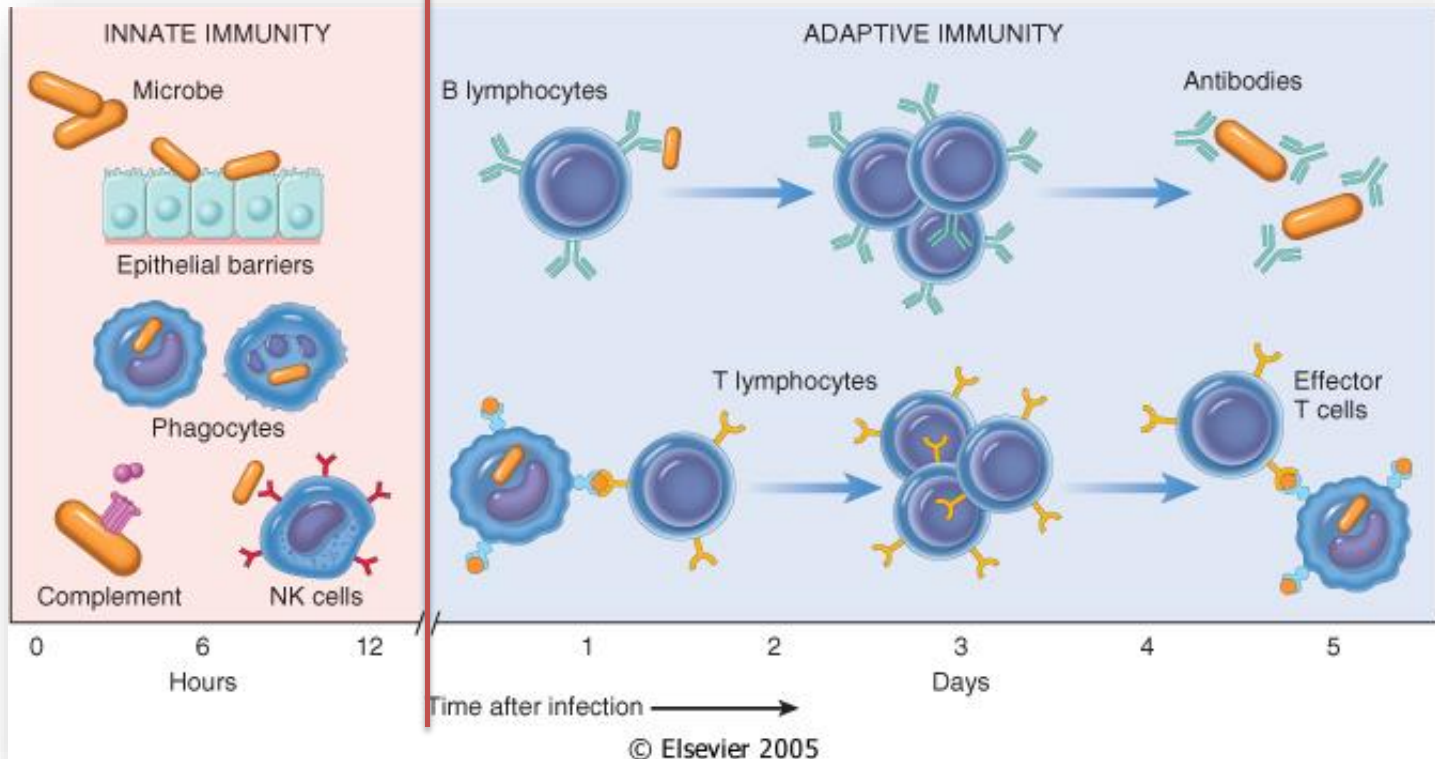

Ανοσιακή απάντηση

Μη ειδική, έμφυτη (Innate)

Ειδική, προσαρμοστική (Adaptive)

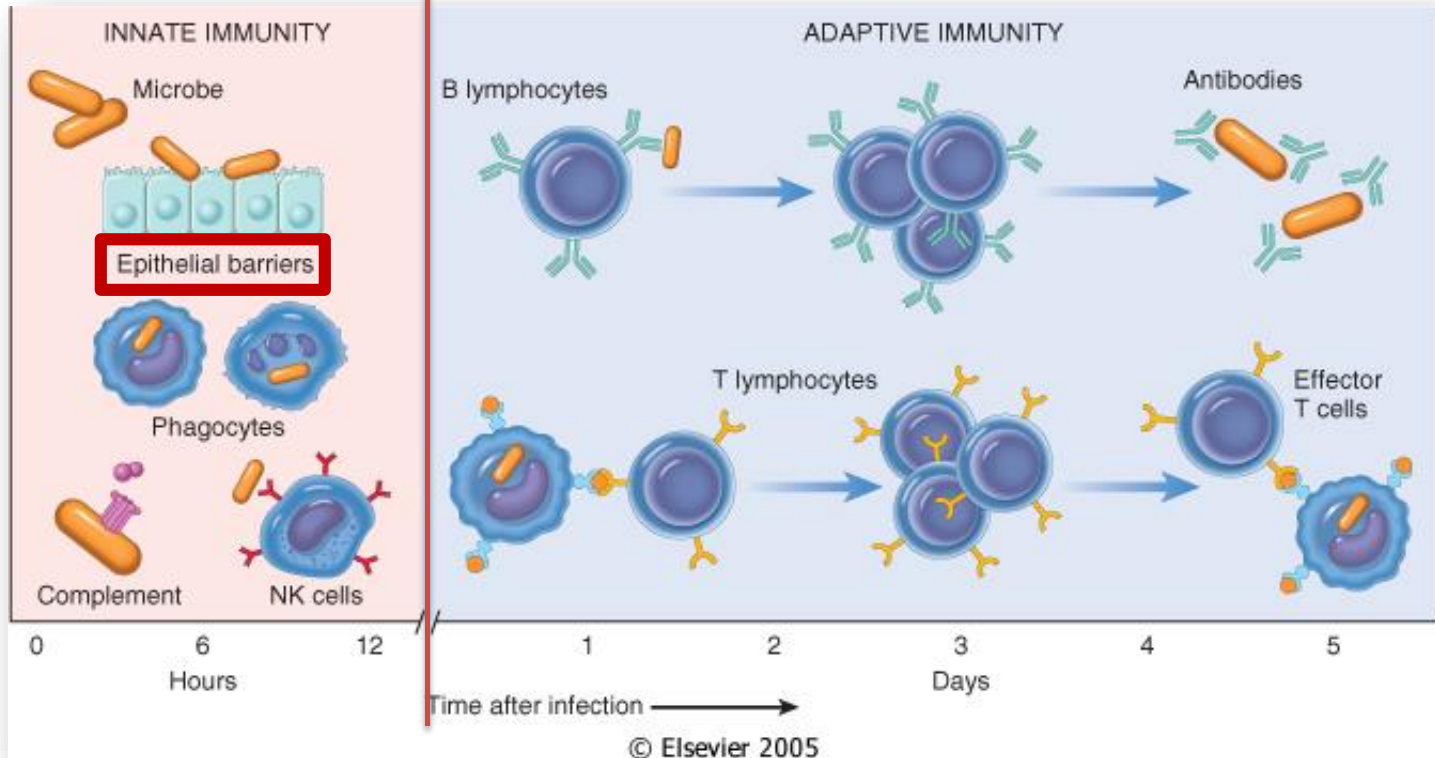

• Επιθηλιακοί φραγμοί

Ανοσιακή απάντηση

Μη ειδική, έμφυτη (Innate)

Ειδική, προσαρμοστική (Adaptive)

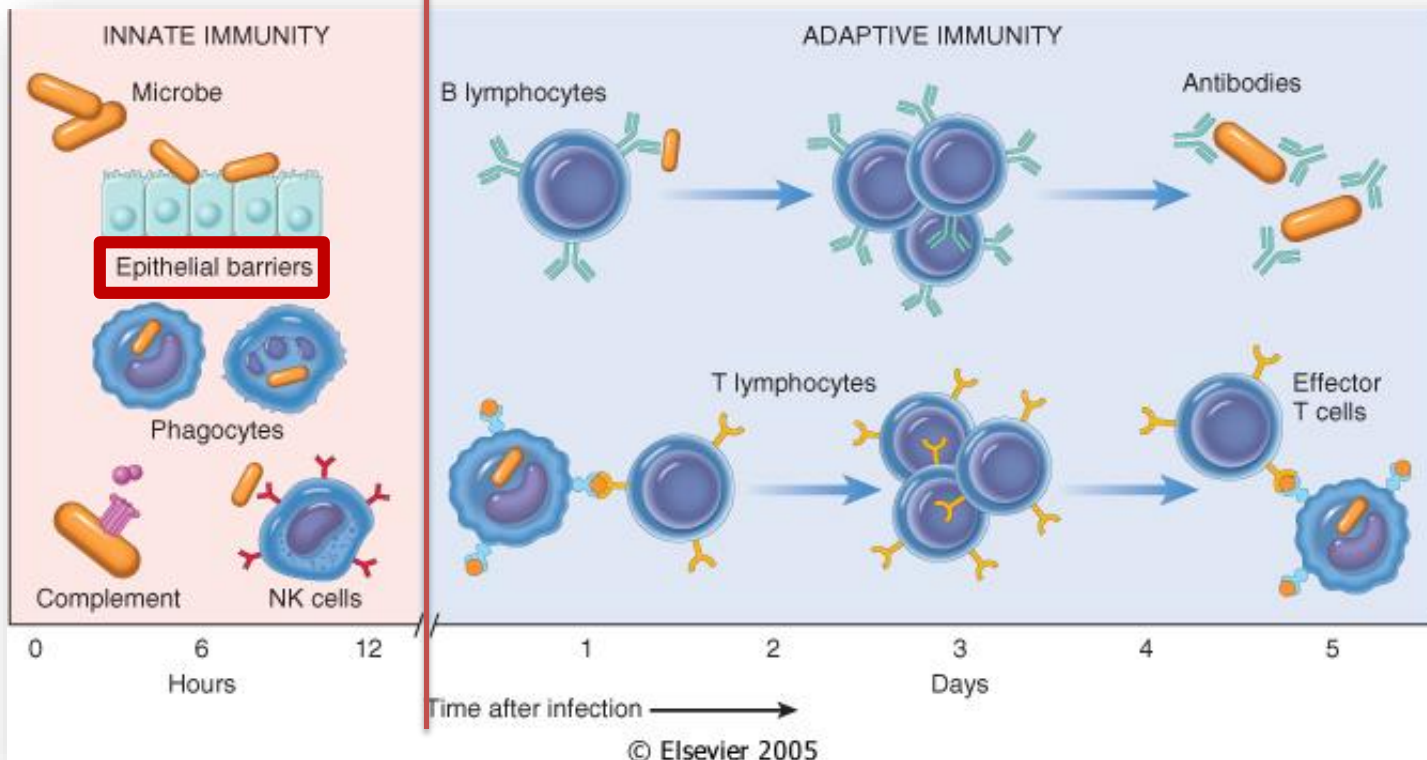

- Επιθηλιακοί φραγμοί
- Φαγοκύτταρα
- NK κύτταρα
- Συμπλήρωμα

Μακροφάγα

- Τοπικοί φρουροί στις πύλες εισόδου μικροβίων (δέρμα, πνεύμονες, βλεννογόνοι)
- Ενεργοποιούνται μετά από αναγνώριση μέσω επιφανειακών υποδοχέων (π.χ. LPS receptor, mannose receptor, TLRs) συστατικά του εξωτερικού τοιχώματος μικροβίων (π.χ. *LPS*, *mannose* etc).
- Στην ενεργοποιημένη τους μορφή καταστρέφουν τον εισβολέα μέσω φαγοκυττάρωσης
- Παράγουν την κυτταροκίνη TNF (ο *TNF* καταστρέφει μολυσμένα κύτταρα από ιούς καθώς και καρκινικά κύτταρα και συμβάλλει στη ενεργοποίηση άλλων ανοσολογικών συντελεστών όπως NK κύτταρα)
- Ενεργοποιούνται και από την IFN- γ

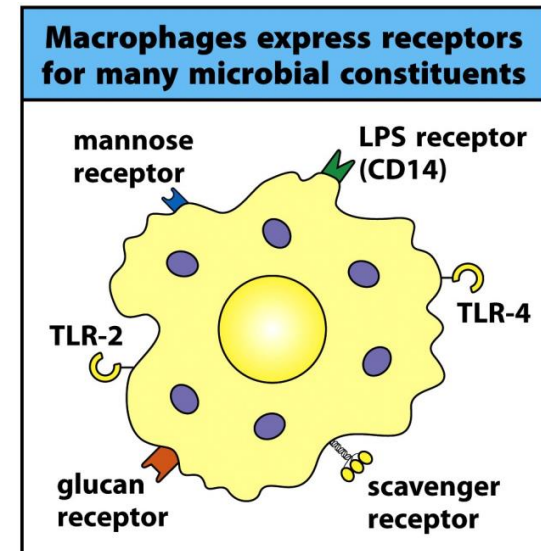

Μακροφάγα

Binding of bacteria to phagocytic receptors on macrophages induces their engulfment and degradation

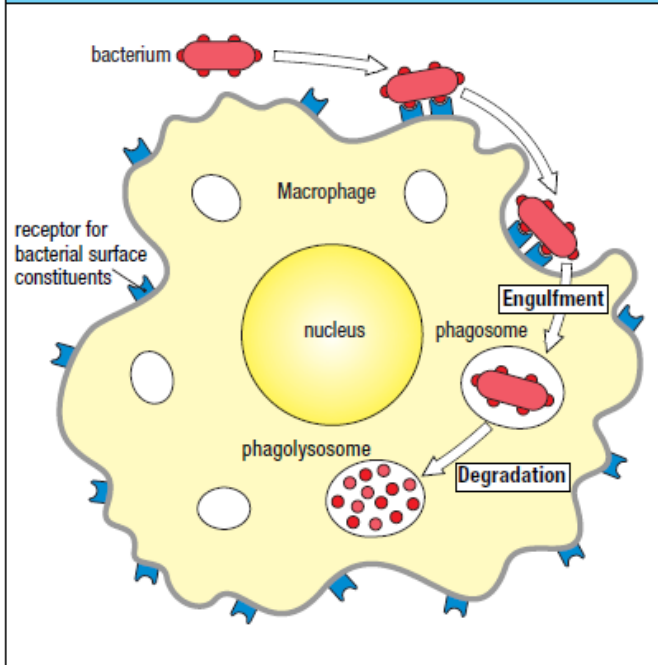

Binding of bacterial components to signaling receptors on macrophages induces the synthesis of inflammatory cytokines

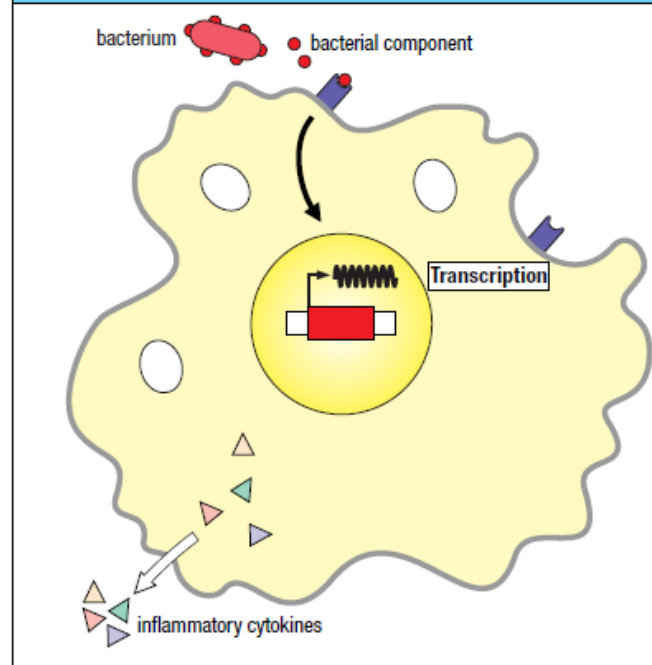
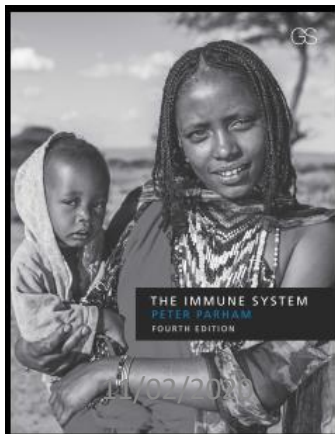

Figure 1.16 Macrophages respond to pathogens by using different receptors to stimulate phagocytosis and cytokine secretion. The left panel shows receptor-mediated phagocytosis of bacteria by a macrophage. The bacterium (red) binds to cell-surface receptors (blue) on the macrophage, inducing engulfment of the bacterium into an internal vesicle called a phagosome within the macrophage cytoplasm. Fusion of the phagosome with lysosomes forms an acidic vesicle called a phagolysosome, which contains toxic small molecules and hydrolytic enzymes that kill and degrade the bacterium. The right panel shows how a bacterial component binding to a different type of cell-surface receptor sends a signal to the macrophage's nucleus that initiates the transcription of genes for inflammatory cytokines. The cytokines are synthesized in the cytoplasm and secreted into the extracellular fluid.



Ουδετερόφιλα πολυμορφοπύρρηνα

- Ιδιαίτερα δραστικά φαγοκύτταρα στην ενεργοποιημένη μορφή (εκτελεστές) με μικρή διάρκεια ζωής
- Παράγουν και απελευθερώνουν ισχυρές δραστικές ουσίες (*λυσσοσωματικά ένζυμα, ρίζες οξυγόνου*) και κυτταροκίνες όπως TNF
- Αναγνώριση βλαπτικών παραγόντων μέσω υποδοχέων PRR (pattern recognition receptors) . Σημαντικότεροι υποδοχείς τύπου Toll (TLR)

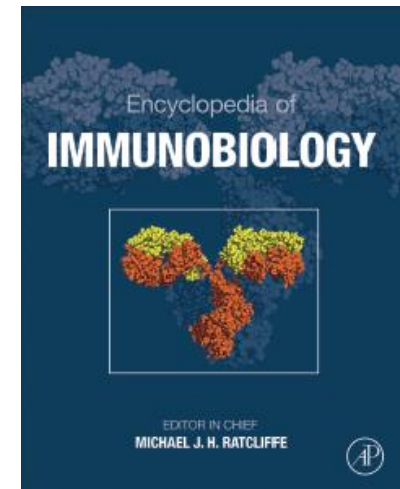
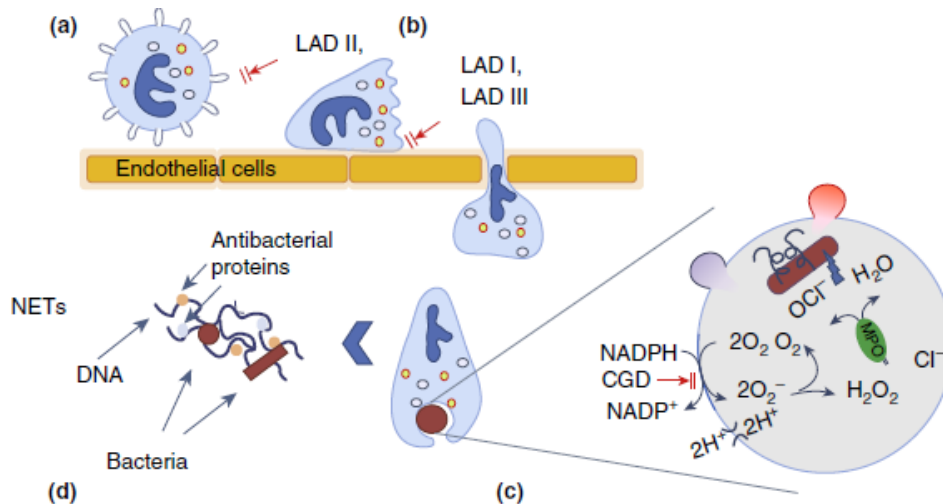

Figure 1 (a) Neutrophils roll on activated endothelial cells, with their attachment being provided by selectins and their ligands (defective in leukocyte adhesion deficiencies (LAD) II). (b) Neutrophils adhere firmly to endothelial cells and migrate toward tight junctions (defective in LAD I and III). (c) Neutrophils phagocytize microorganisms, and (*blow-up*) use NADPH oxidase (defective in chronic granulomatous disease (CGD)) to drive formation of hypochlorous acid for killing of microbes and fusion of granules that empty their contents of bactericidal peptides to kill microbes.

(d) neutrophil extracellular traps (NETs), strands of extracellular DNA with antimicrobial proteins attached, which capture and possibly kill microbes.

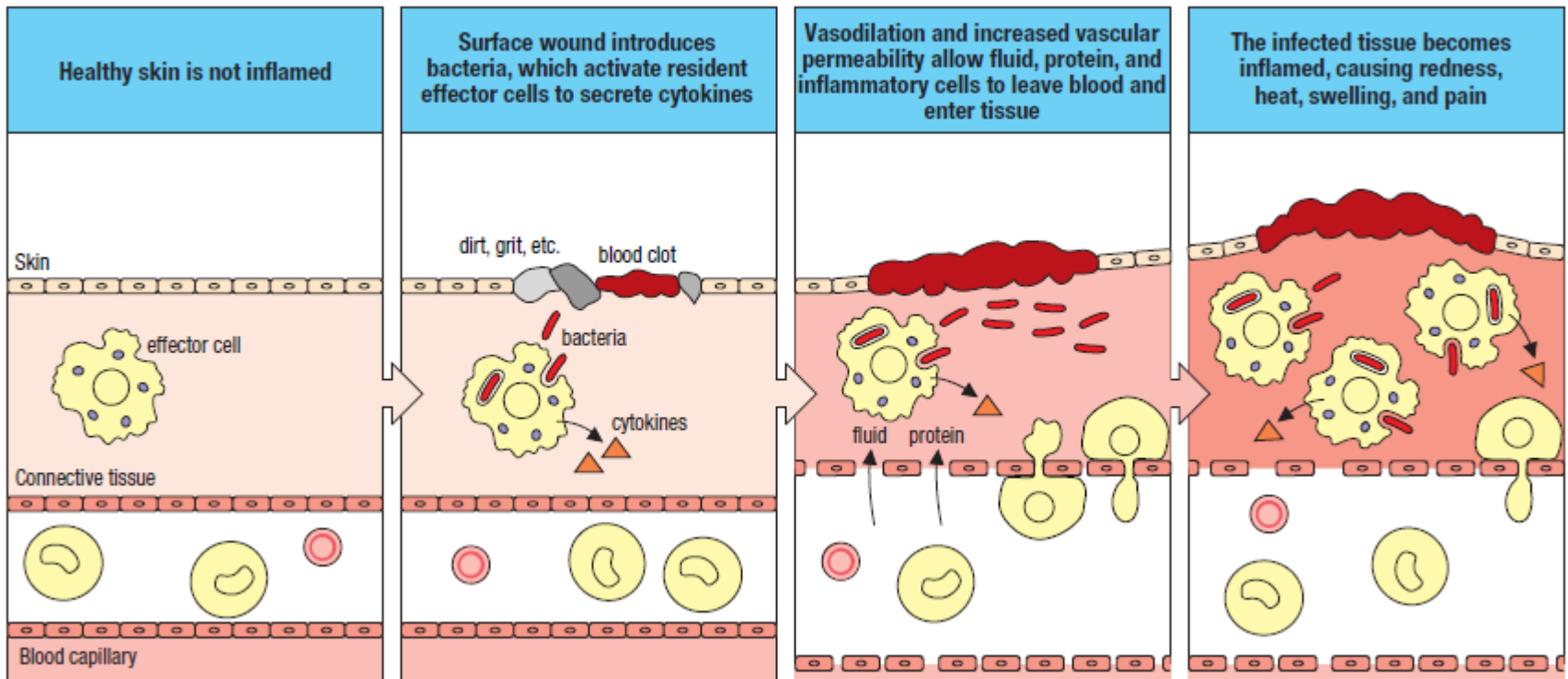
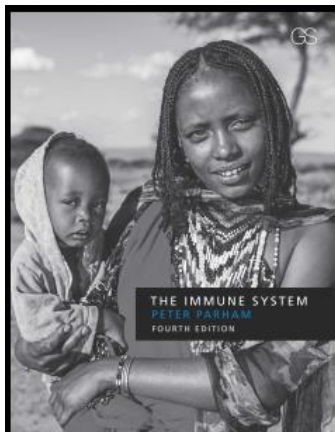

Figure 1.7 Innate immune mechanisms establish a state of inflammation at sites of infection. Illustrated here are the events following an abrasion of the skin. Bacteria invade the underlying connective tissue and stimulate the innate immune response.



Ανοσιακή απάντηση

Μη ειδική, έμφυτη (Innate)

Ειδική, προσαρμοστική (Adaptive)

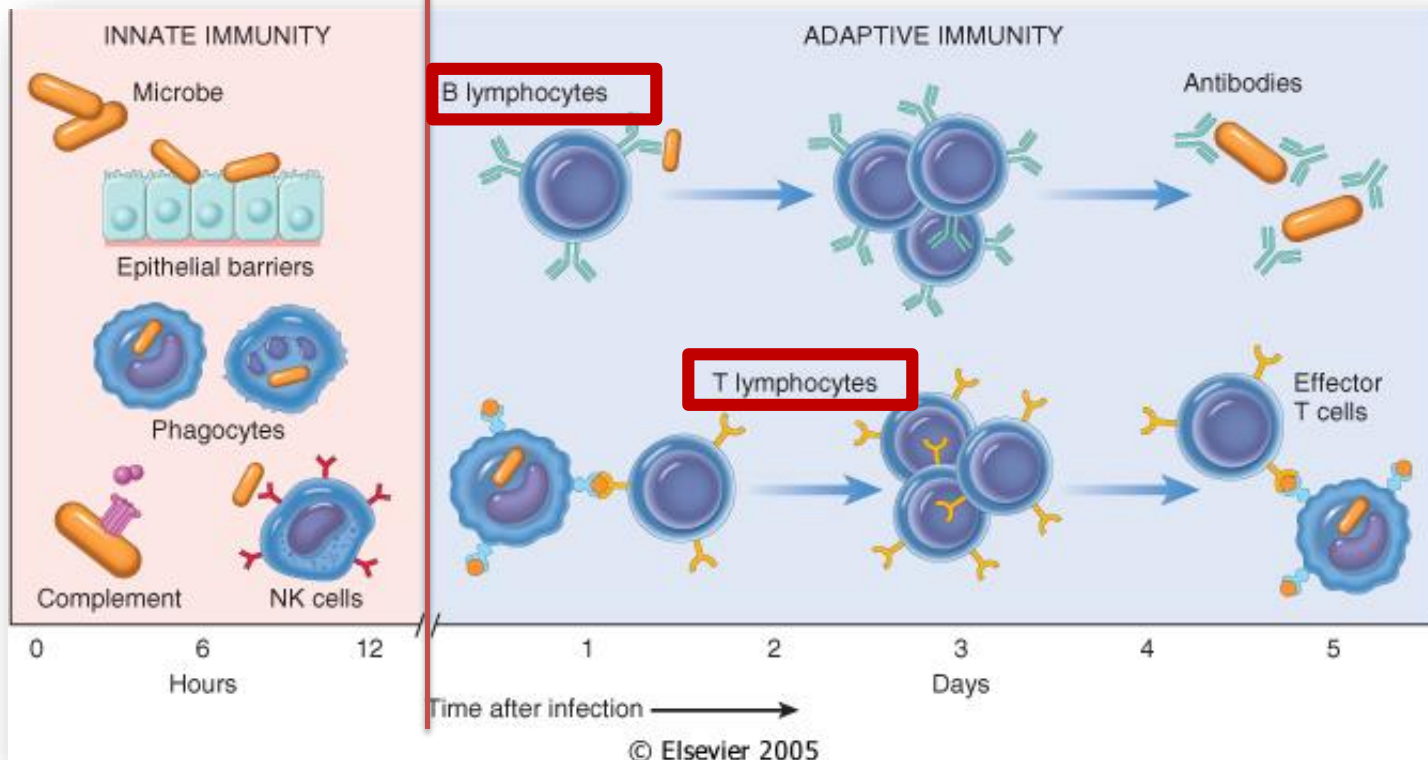

- Επιθηλιακοί φραγμοί
- Φαγοκύτταρα
- NK κύτταρα
- Συμπλήρωμα

Adaptive memory

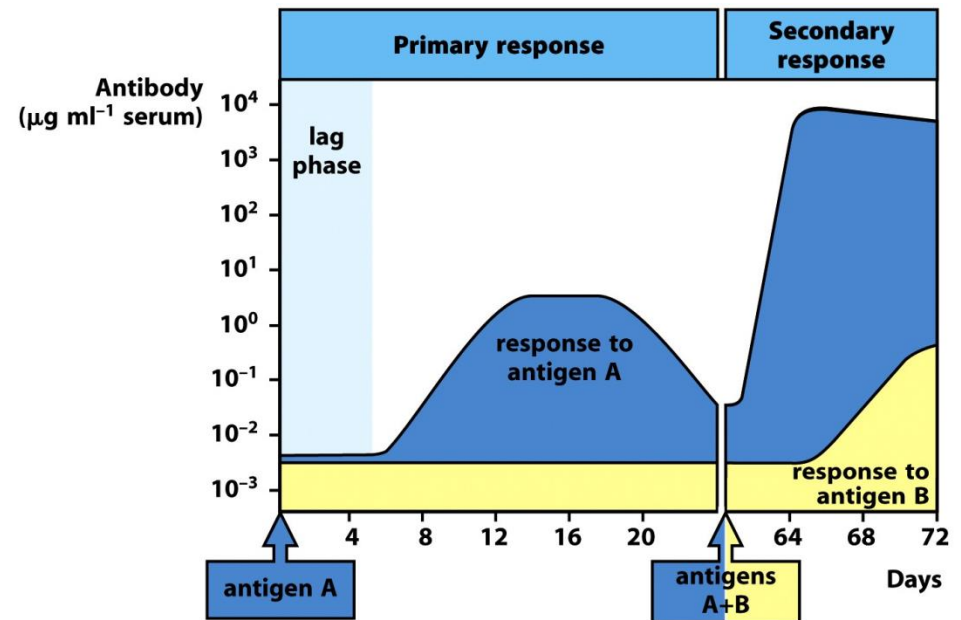

Figure 1-24 Immunobiology, 7ed. (© Garland Science 2008)

Memory: The property of the adaptive immune system to respond more rapidly, with greater magnitude, and more effectively to a repeated exposure to an antigen compared with the response to the first exposure.

Innate memory ?

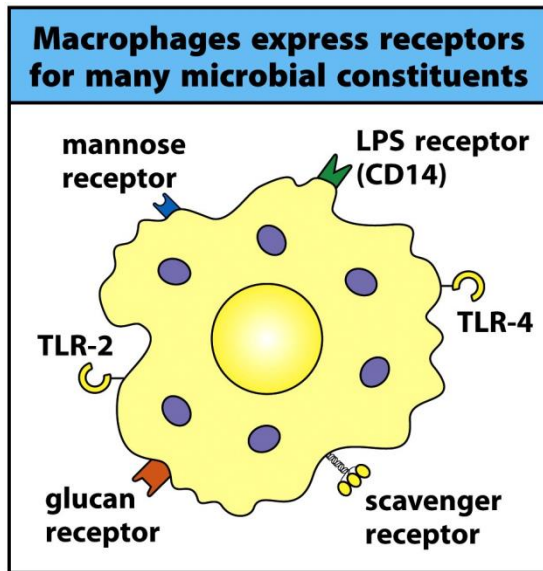

Figure 1-10 Immunobiology, 7ed. (© Garland Science 2008)

Adaptive memory

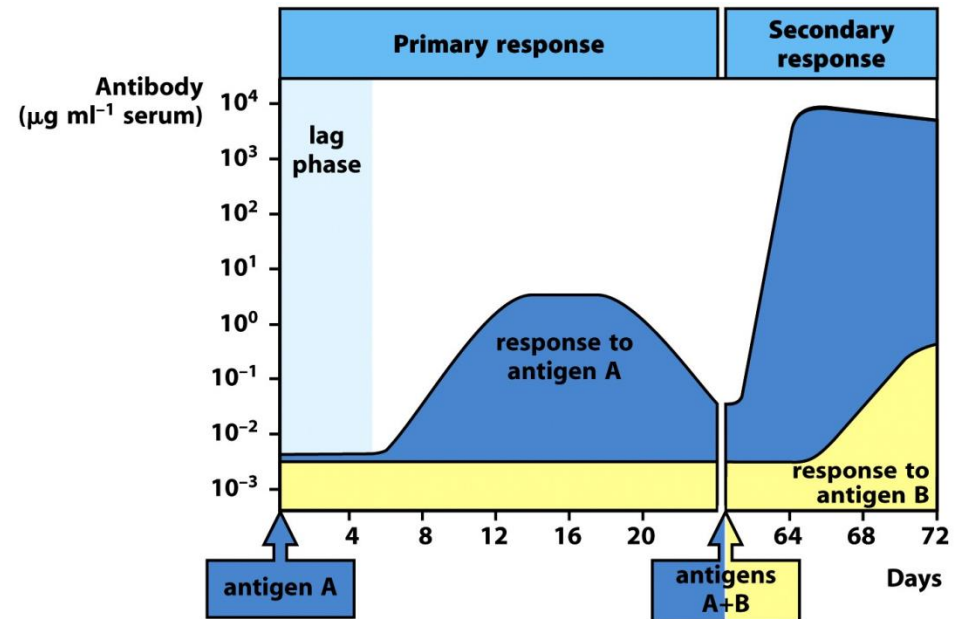

Figure 1-24 Immunobiology, 7ed. (© Garland Science 2008)

Memory: The property of the **adaptive immune system** to respond more rapidly, with greater magnitude, and more effectively to a repeated exposure to an antigen compared with the response to the first exposure.

- Το σύστημα ειδικής (χυμικής και κυτταρικής) ανοσίας είναι **γενετικά προσηδιασμένο** για την αναγνώριση και τη στοχευμένη προσβολή του/κάθε ξένου βλαπτικού παράγοντα
- Απαντάται μόνο στα σπονδυλωτά ζώα

Ειδική ανοσιακή απάντηση

Χυμική

Κυτταρική

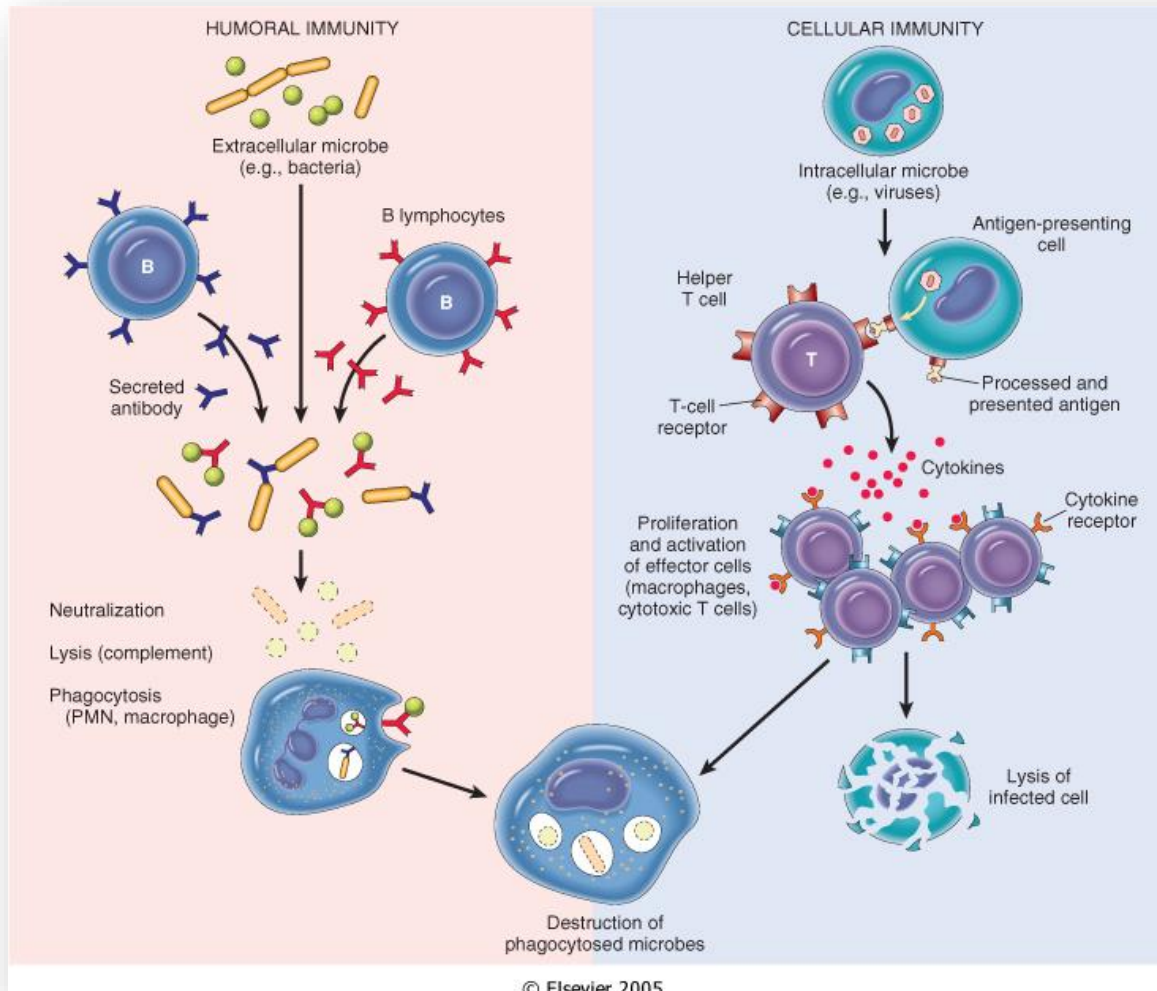

Ειδική ανοσιακή απάντηση

Χυμική

Κυτταρική

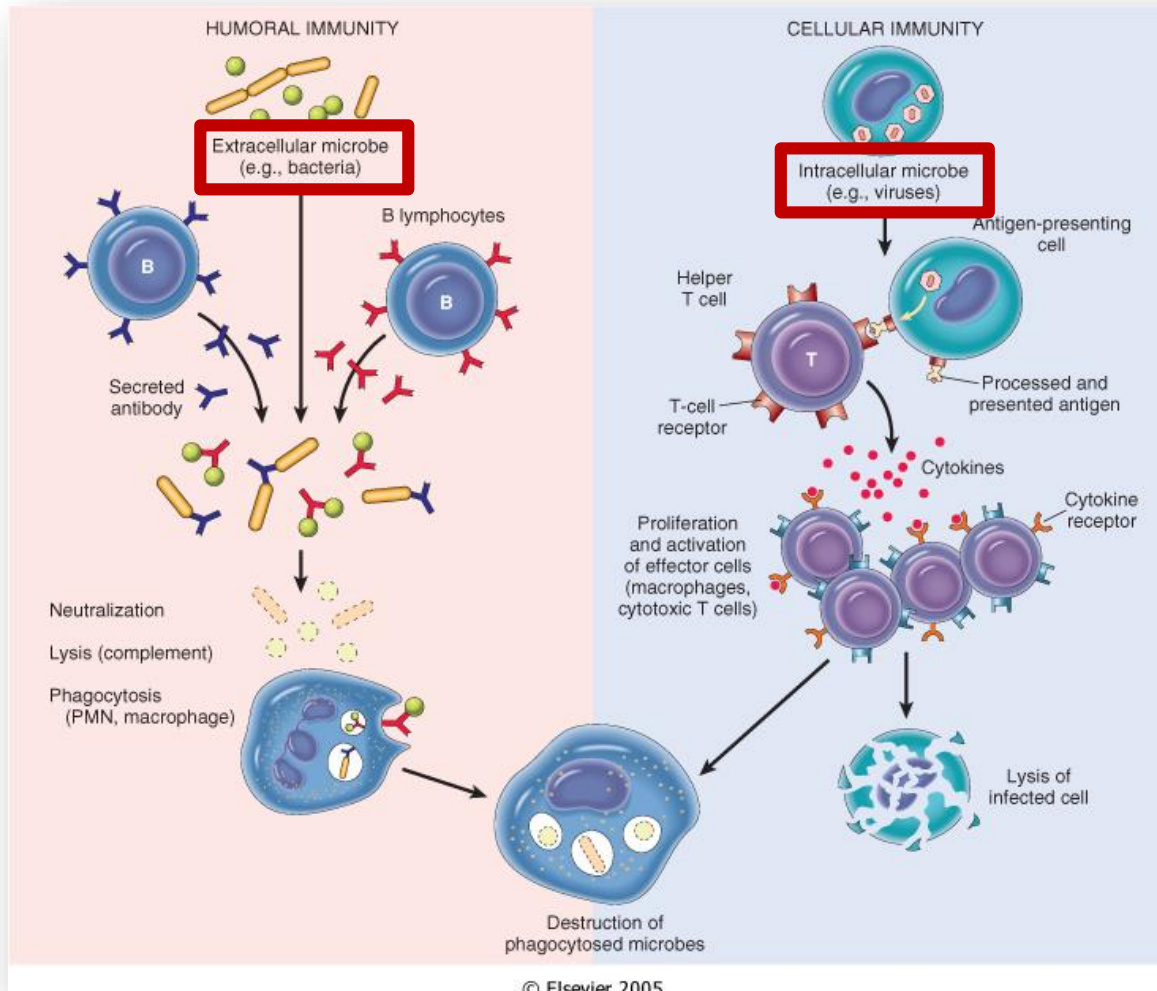

Ειδική ανοσιακή απάντηση

Χυμική

Κυτταρική

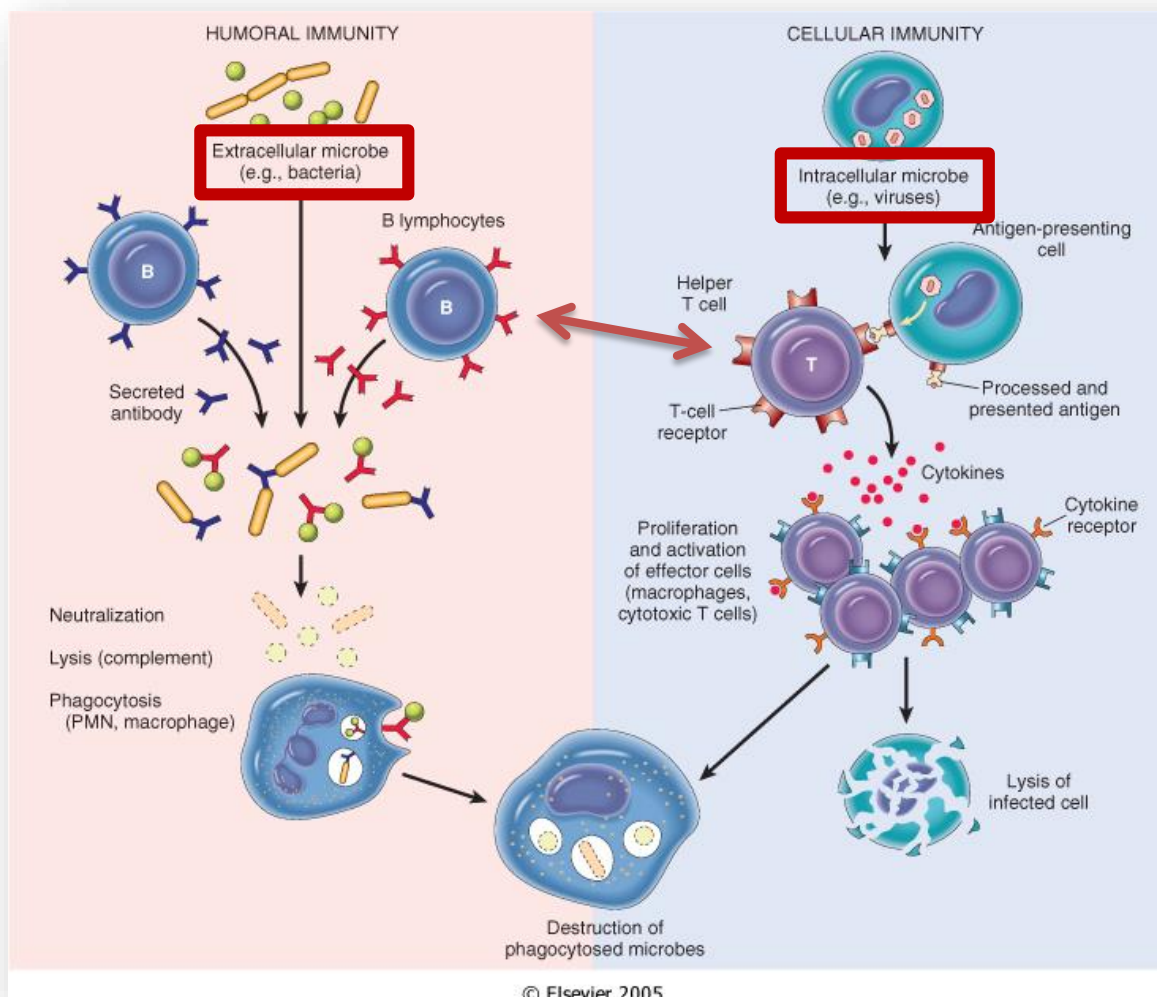

1. Τύποι (τάξεις) αντισωμάτων

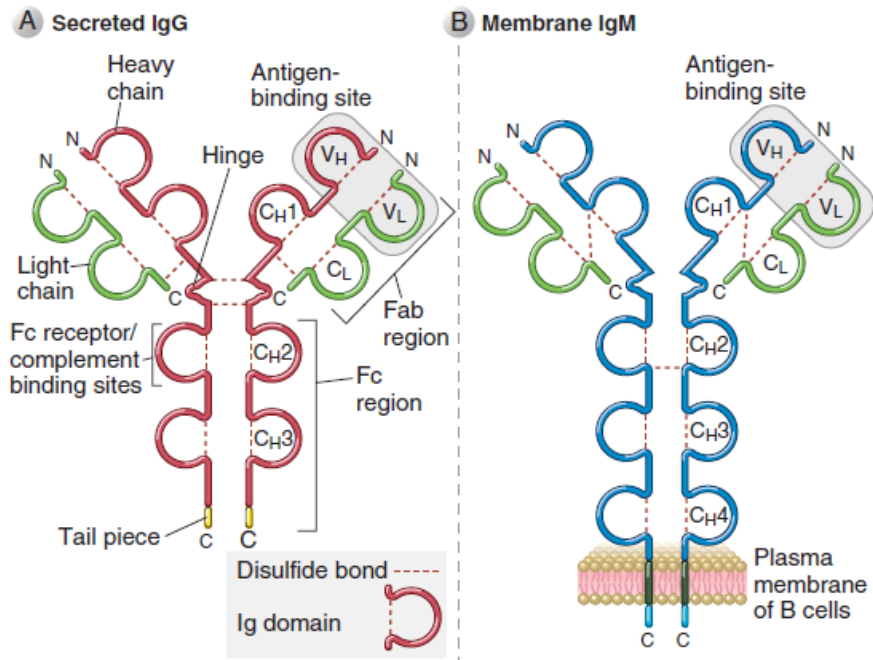
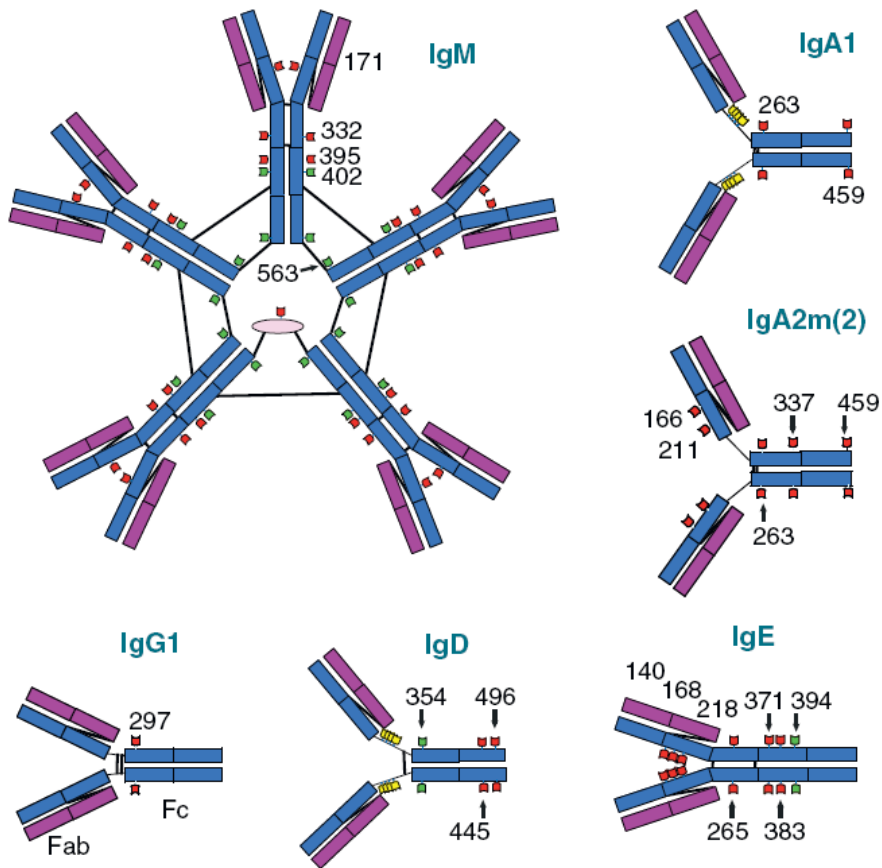

1. Τύποι (τάξεις) αντισωμάτων

TABLE 5.2 Human Antibody Isotypes

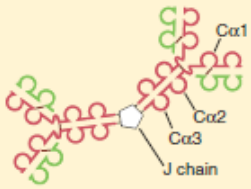
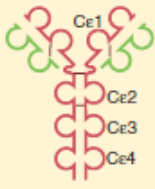
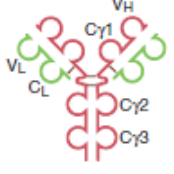
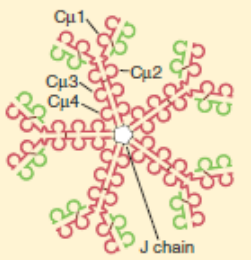
Isotype of Antibody	Subtypes (H chain)	Plasma Concentration (mg/mL)	Half-Life (days)	Secreted Form	Diagram	Functions
IgA	IgA1,2 (α 1 or α 2)	3.5	6	Mainly dimer; also monomer, trimer		Mucosal immunity
IgD	None (δ)	Trace	3	Monomer		B cell antigen receptor
IgE	None (ϵ)	0.05	2	Monomer		Defense against helminthic parasites, immediate hypersensitivity
IgG	IgG1-4 (γ 1, γ 2, γ 3, or γ 4)	13.5	23	Monomer		Opsonization, complement activation, antibody-dependent cell-mediated cytotoxicity, neonatal immunity, feedback inhibition of B cells
IgM	None (μ)	1.5	5	Pentamer		Naive B cell antigen receptor (monomeric form), complement activation

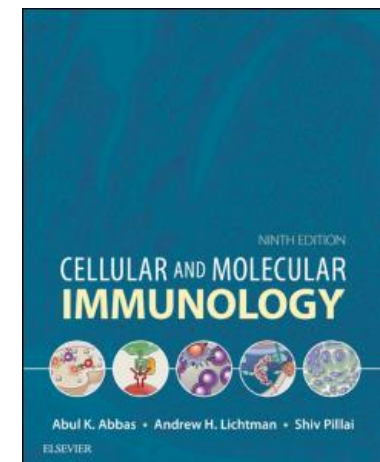

1. Τύποι (τάξεις) αντισωμάτων

TABLE 13.2 Functions of Antibody Isotypes

Antibody Isotype	Isotype-Specific Effector Functions
IgG	Opsonization of antigens for phagocytosis by macrophages and neutrophils Activation of the classical pathway of complement Antibody-dependent cell-mediated cytotoxicity mediated by natural killer cells Neonatal immunity: transfer of maternal antibody across the placenta and gut Feedback inhibition of B cell activation Neutralization of microbes and toxins
IgM	Activation of the classical pathway of complement
IgA	Mucosal immunity: secretion of IgA into the lumens of the gastrointestinal and respiratory tracts Neutralization of microbes and toxins in lumens of mucosal organs
IgE	Mast cell degranulation (immediate hypersensitivity reactions) Eosinophil-mediated defense against helminths

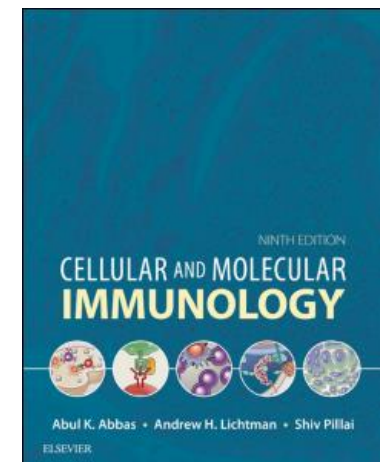

ΧΥΜΙΚΗ ΑΝΟΣΙΑ

2. Δράση αντισωμάτων

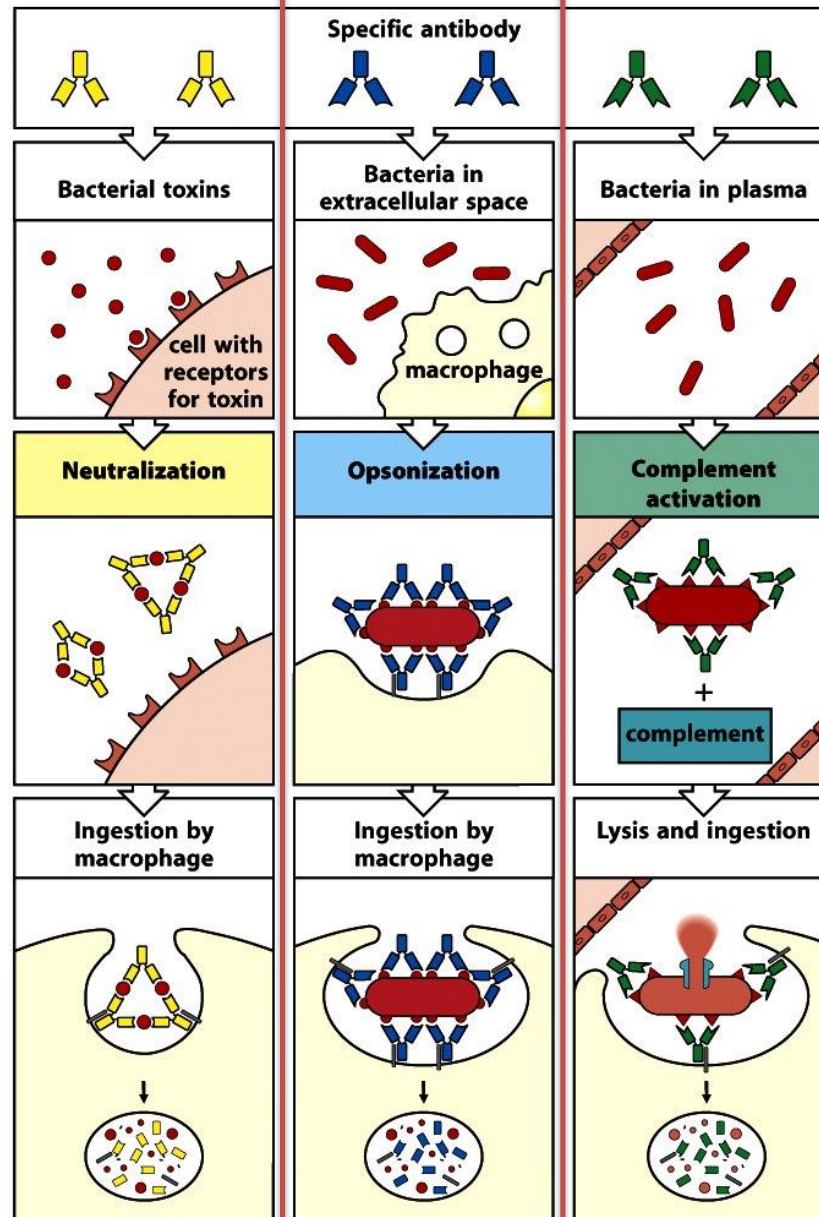

Figure 1-26 Immunobiology, 7ed. (© Garland Science 2008)

ΧΥΜΙΚΗ ΑΝΟΣΙΑ

2. Δράση αντισωμάτων

▪ Εξουδετέρωση

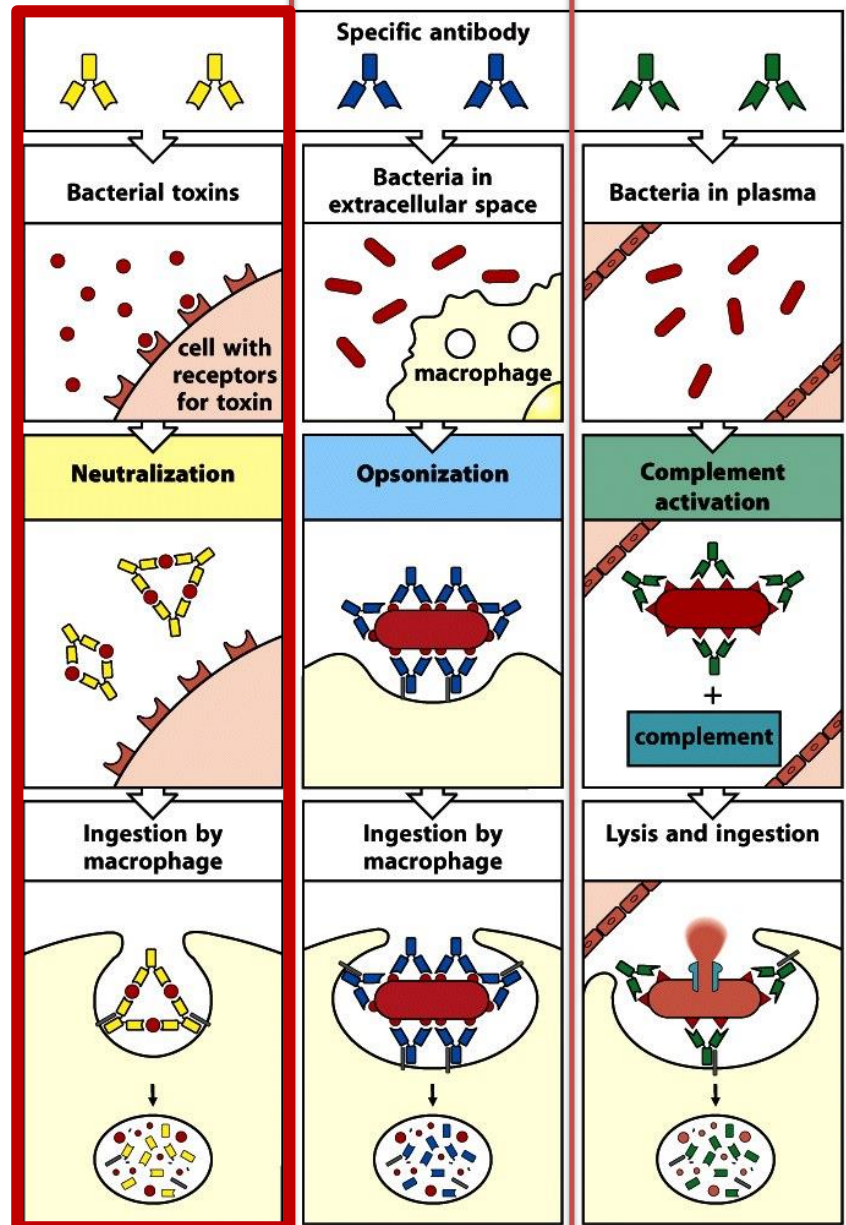

Figure 1-26 Immunobiology, 7ed. (© Garland Science 2008)

ΧΥΜΙΚΗ ΑΝΟΣΙΑ

2. Δράση αντισωμάτων

▪ Οψωνοποίηση

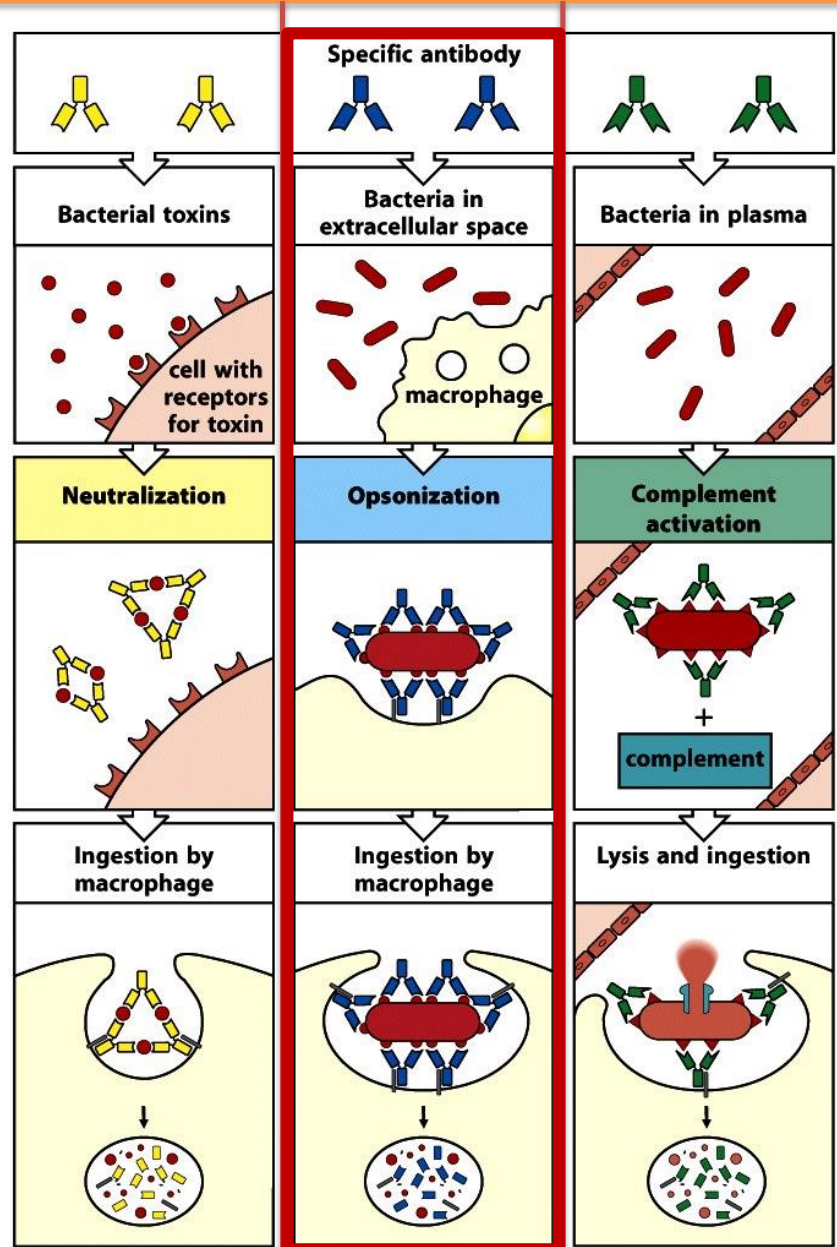

Figure 1-26 Immunobiology, 7ed. (© Garland Science 2008)

ΧΥΜΙΚΗ ΑΝΟΣΙΑ

2. Δράση αντισωμάτων

- Ενεργοποίηση συμπληρώματος

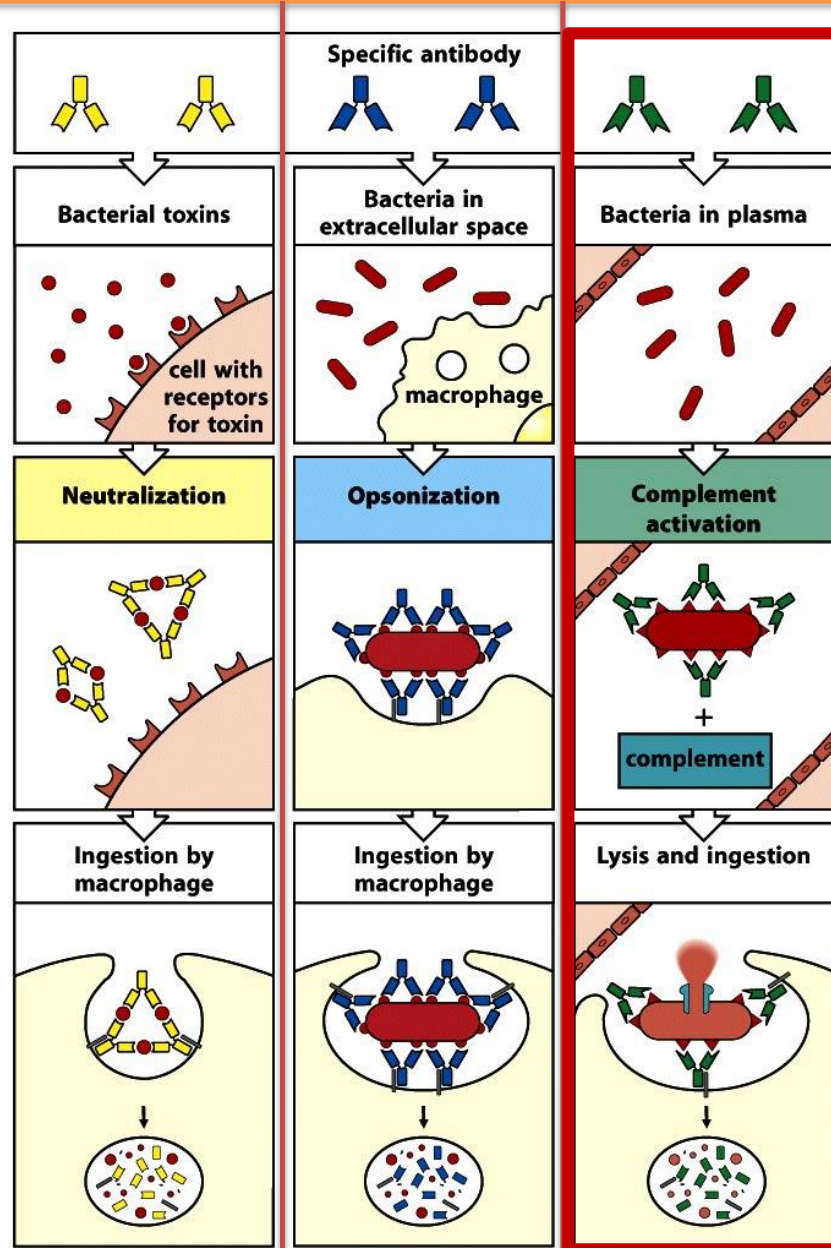

Figure 1-26 Immunobiology, 7ed. (© Garland Science 2008)

Συμπλήρωμα

- Το σύστημα του συμπληρώματος δρα με μεγάλη ταχύτητα
- Οι πρωτεΐνες του συστήματος βρίσκονται σε υψηλές πυκνότητες στο αίμα και στους ιστούς
- Προσβάλλει εισβολείς με περίσσιες ομάδες OH ή αμινών στην επιφάνειά τους
- Κάθε μη προστατευμένη επιφάνεια αποτελεί στόχο
- Διαφορετικές (≥ 4) οδοί ενεργοποίησης

Συμπλήρωμα

Ποικίλες λειτουργίες

- **Κυτταρολυτική δράση** μέσω του συμπλέγματος προσβολής μεμβράνης (membrane attack complex, MAC) (σύμπλεγμα C5β, C6, C7, C8, C9, το οποίο δημιουργεί οπές στην κυτταρική μεμβράνη και προκαλεί οσμωτική λύση /υδρόλυση)
- **Οψωνοποίηση** (διεκολύνει τη φαγοκυττάρωση επικαλύπτοντας την επιφάνεια του εισβολέα και συνδεόμενο με ειδικούς υποδοχείς στην επιφάνεια των μακροφάγων / iC3b receptors)
- **Χημειοτακτική δράση (C3a, C5a)**

ΧΥΜΙΚΗ ΑΝΟΣΙΑ

3. Συμπλήρωμα

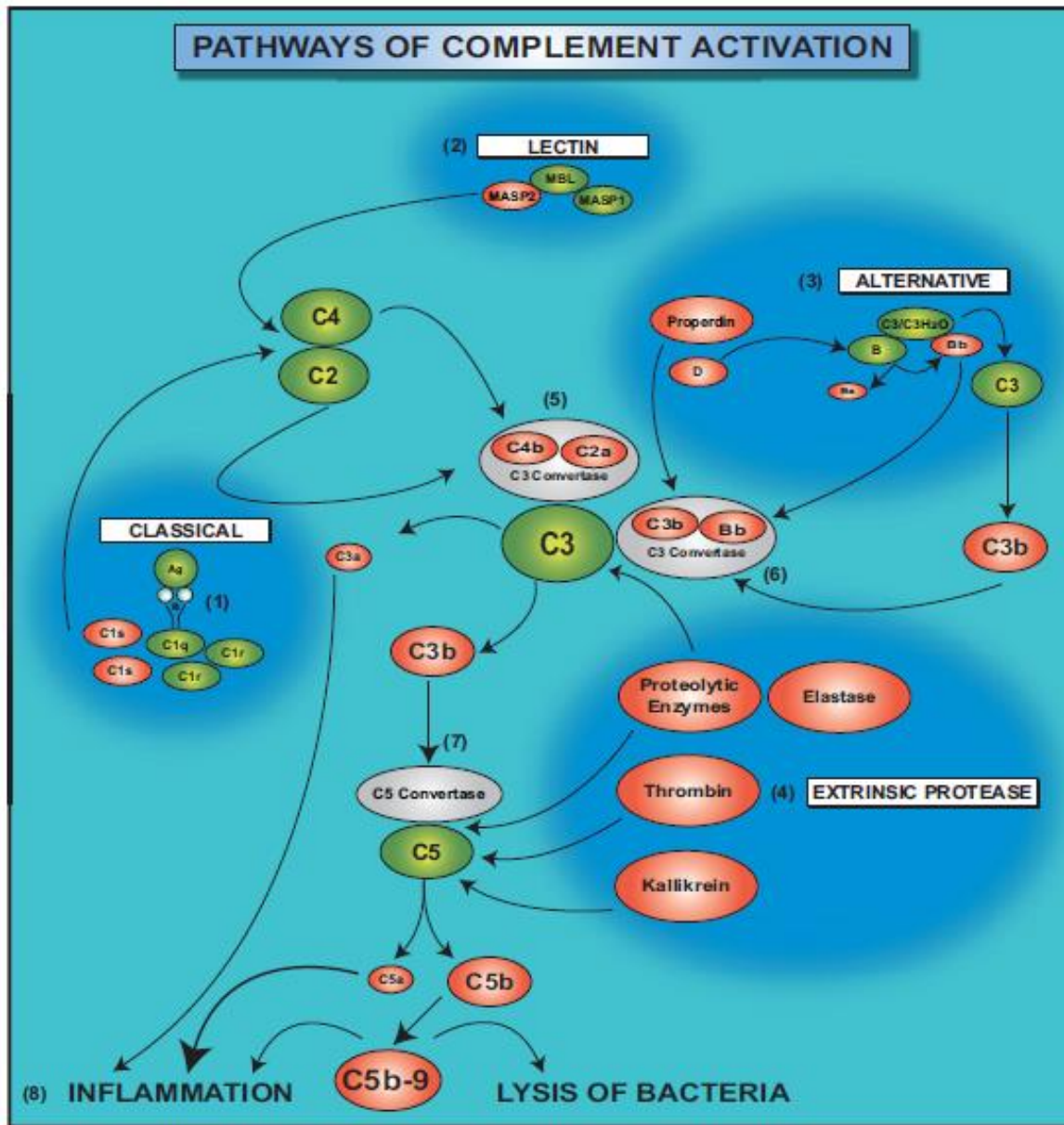

ΧΥΜΙΚΗ ΑΝΟΣΙΑ

3. Συμπλήρωμα

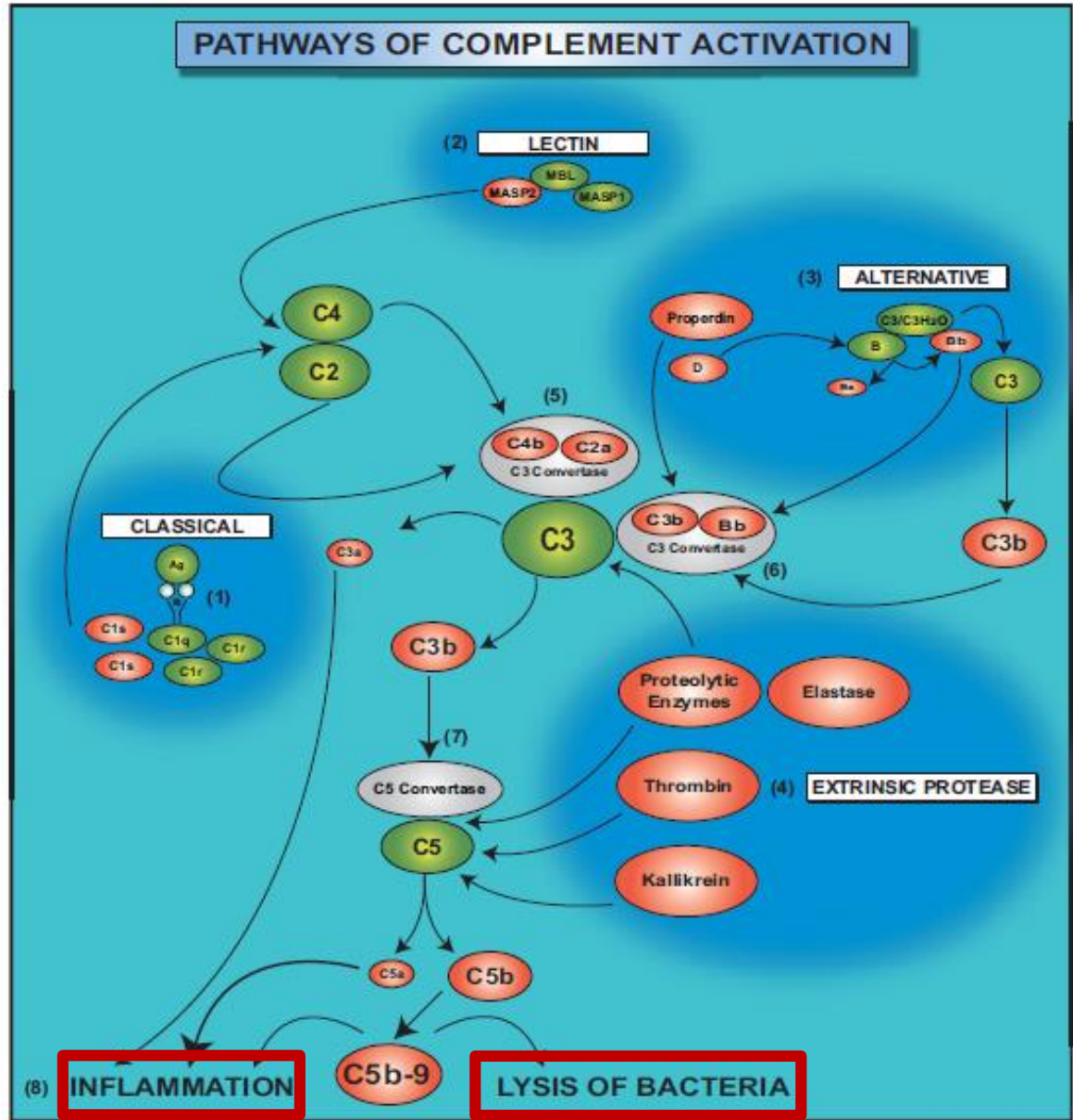

3. Συμπλήρωμα

3.1. Φλεγμονή

3.2. Λύση βακτηριδίων

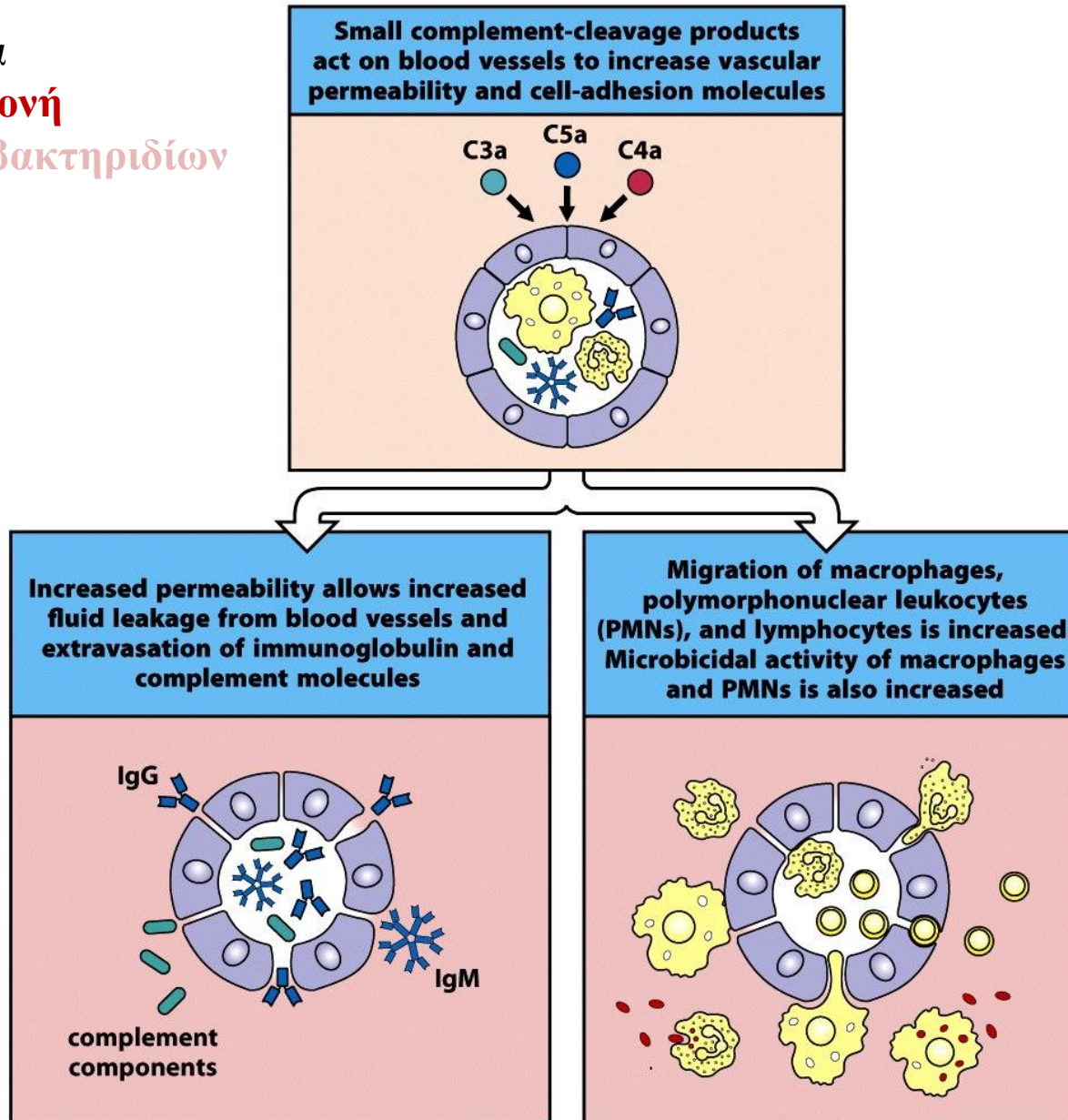
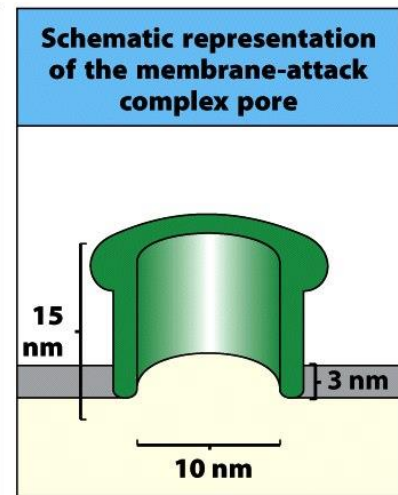
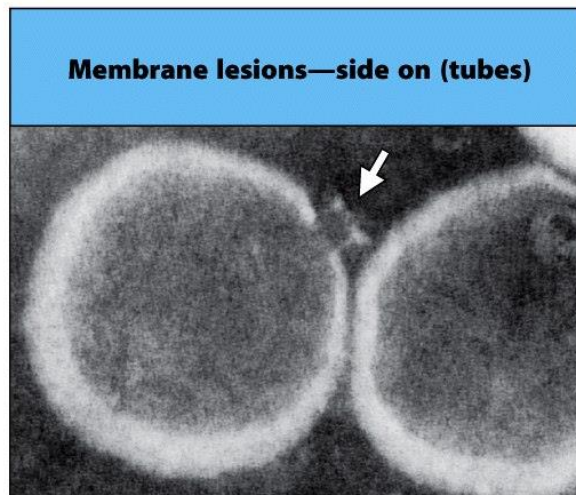
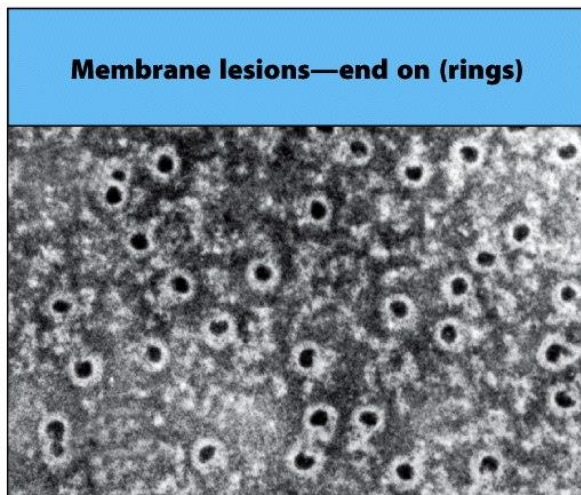
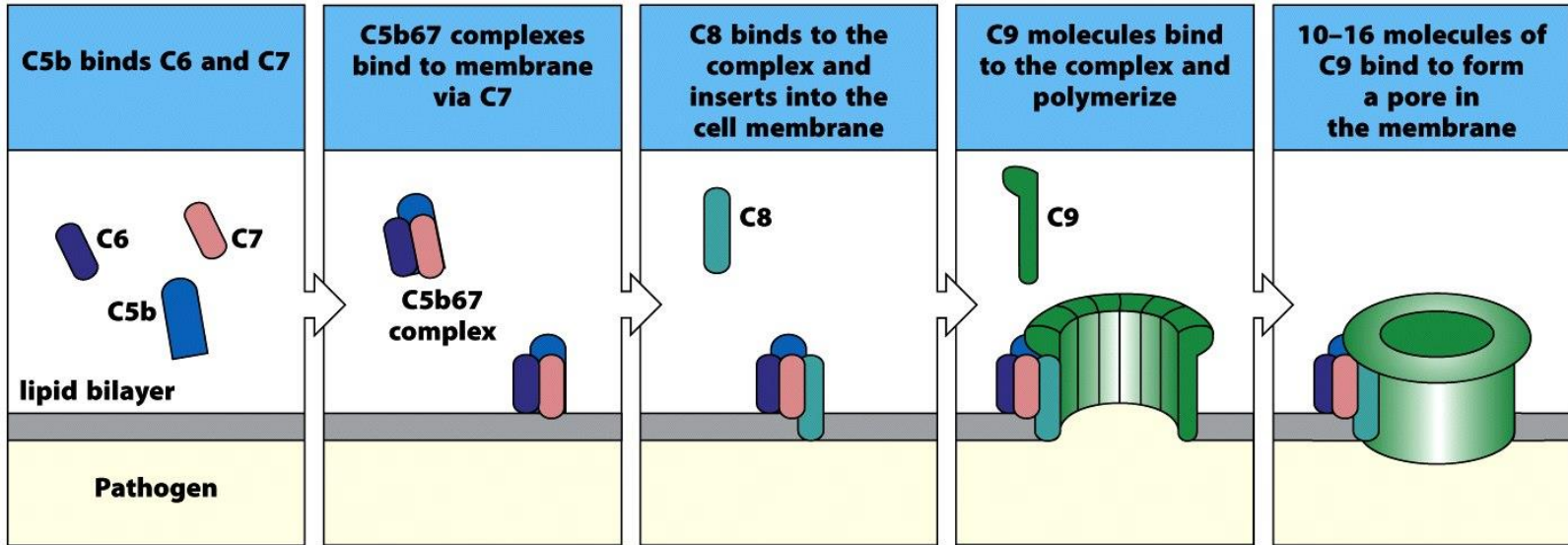

Figure 2-39 Immunobiology, 7ed. (© Garland Science 2008)

3. Συμπλήρωμα

3.1. Φλεγμονή

3.2. Λύση βακτηριδίων



T λεμφοκύτταρα

- Βοηθητικά (T helper, Th)
- Κυτταροτοξικά (T cytotoxic)

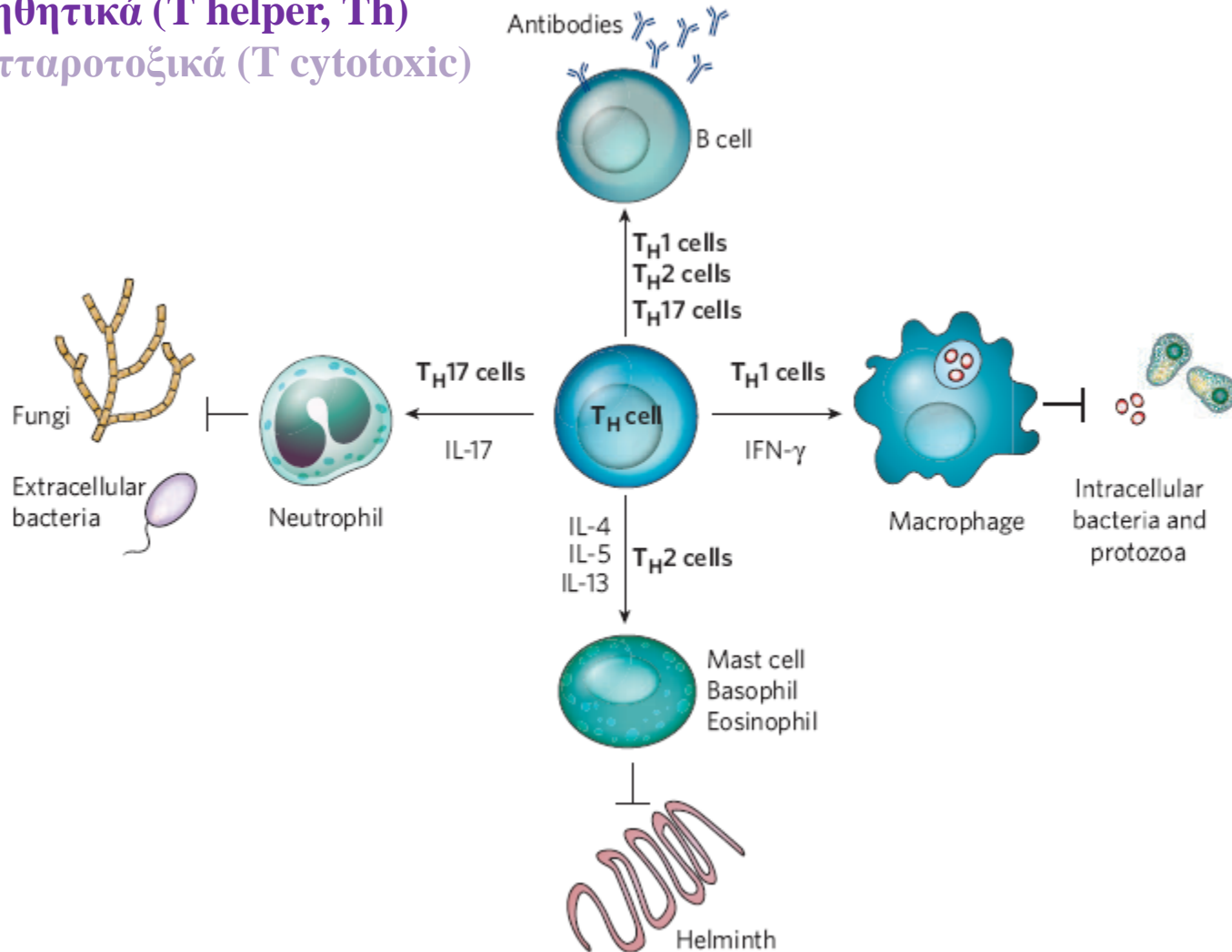

T λεμφοκύτταρα

- Βοηθητικά (T helper, Th)
- Κυτταροτοξικά (T cytotoxic)

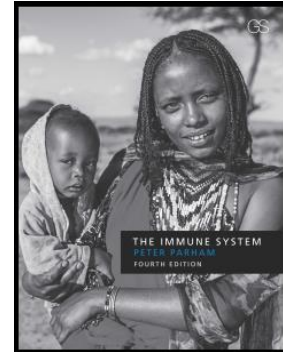



	T _H 1 cells	T _H 17 cells	T _H 2 cells	T _{FH} cells	T regulatory cells (T _{reg})
Effector CD4 T cell					
Cytokines that induce differentiation	IL-12 IFN- γ	IL-6 IL-21	IL-4	IL-16 TGF- β IL-23	TGF- β
Defining transcription factor	T-bet	ROR γ T	GATA3	Bcl6	FoxP3
Characteristic cytokines	IL-12 IFN- γ	IL-17 IL-6	IL-4 IL-5	IL-21	TGF- β IL-10
Function	Activate macrophages	Enhance neutrophil response	Activate cellular and antibody response to parasites	Activate B cells Maturation of antibody response	Suppress other effector T cells

Figure 8.14 Five functional classes of effector CD4 T cell are produced by activation and differentiation in different cytokine environments. Summarized here are the cytokines that induce the different pathways of differentiation, the transcription factors uniquely associated with each pathway, the cytokines made by each type of effector CD4 T cell, and the roles of these cells in the immune response.

Αναγνώριση των αντιγόνων από τα Β και Τ λεμφοκύτταρα

1. Υποδοχέας Β λεμφοκυττάρων (BCR, αντίσωμα επιφανείας)

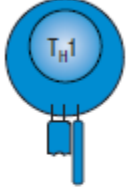

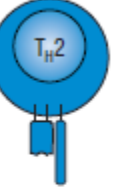
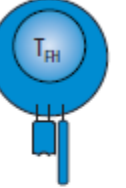
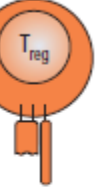
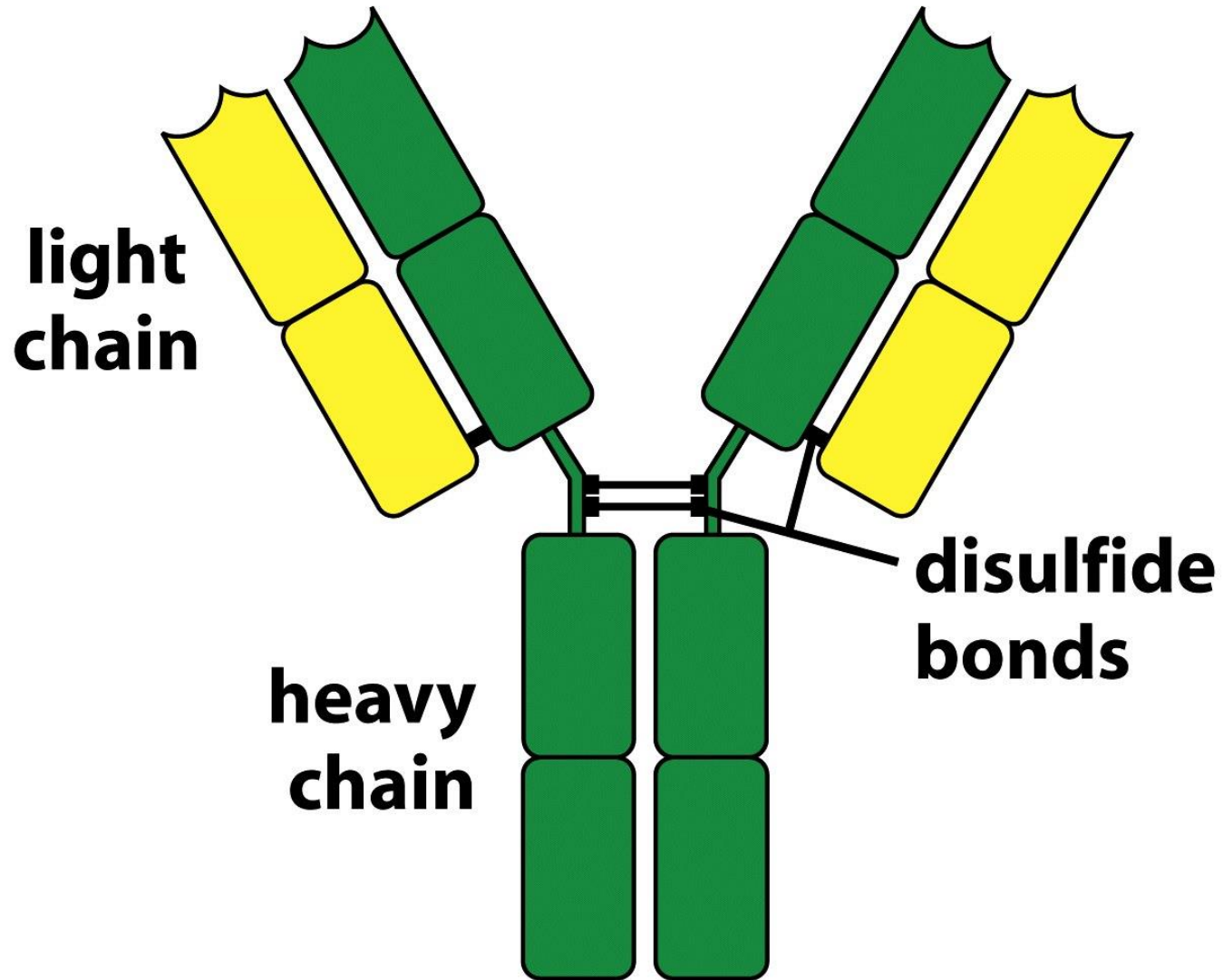
1. Υποδοχέας B λεμφοκυττάρων (BCR, αντίσωμα επιφανείας)

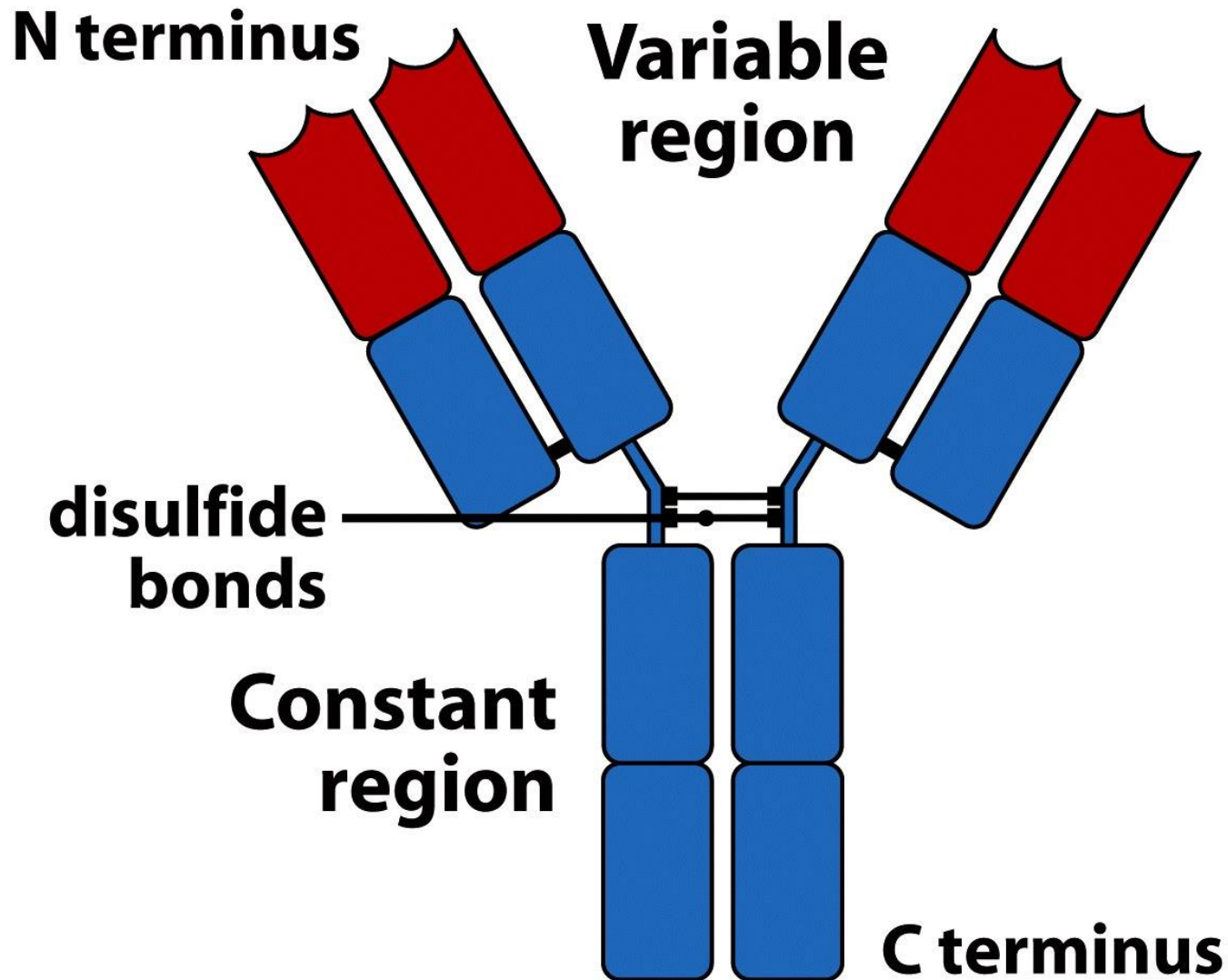

Figure 3-1c Immunobiology, 7ed. (© Garland Science 2008)

1. Υποδοχέας B λεμφοκυττάρων (BCR, αντίσωμα επιφανείας)

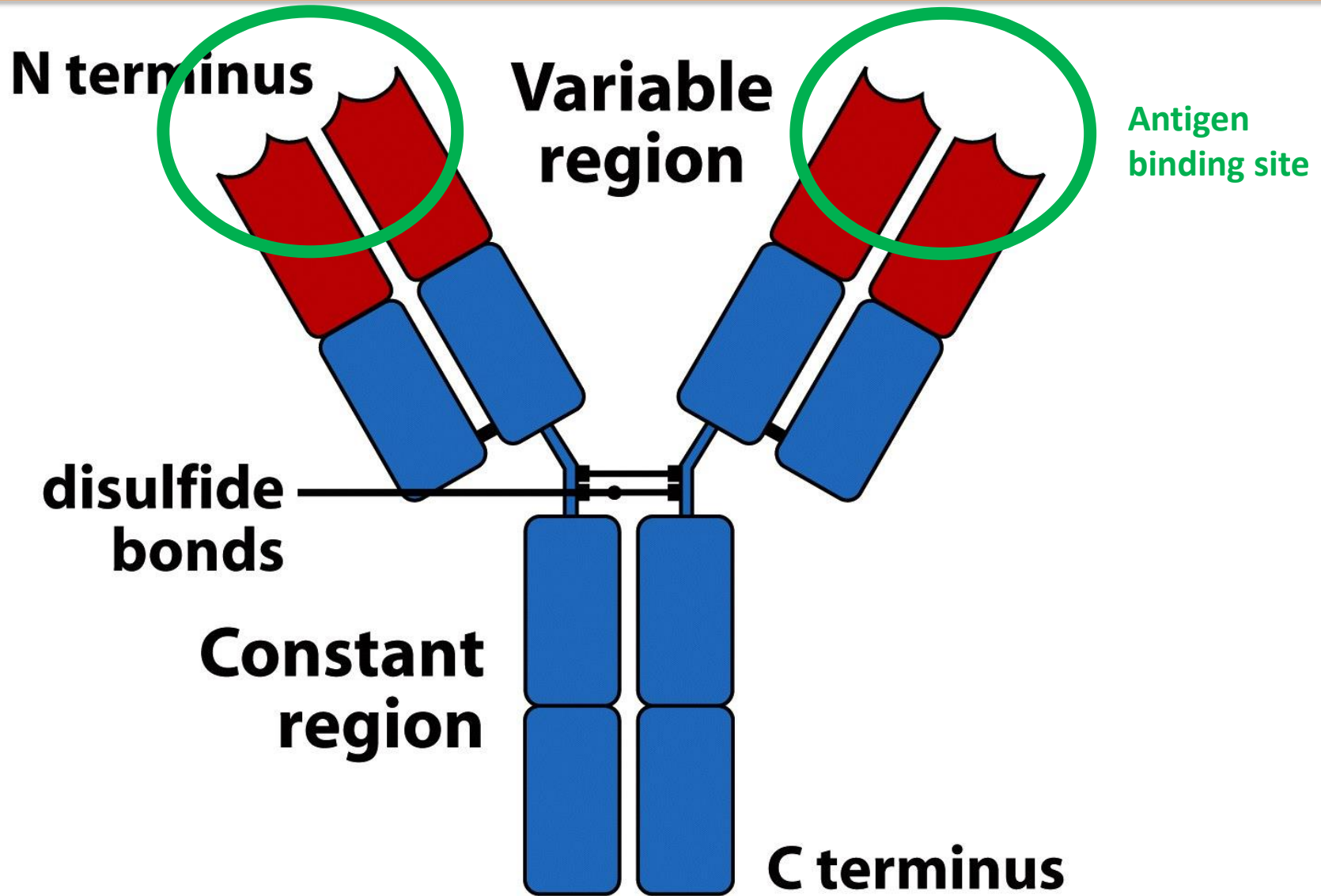

Figure 3-1c Immunobiology, 7ed. (© Garland Science 2008)

1. Υποδοχέας B λεμφοκυττάρων (BCR, αντίσωμα επιφανείας)

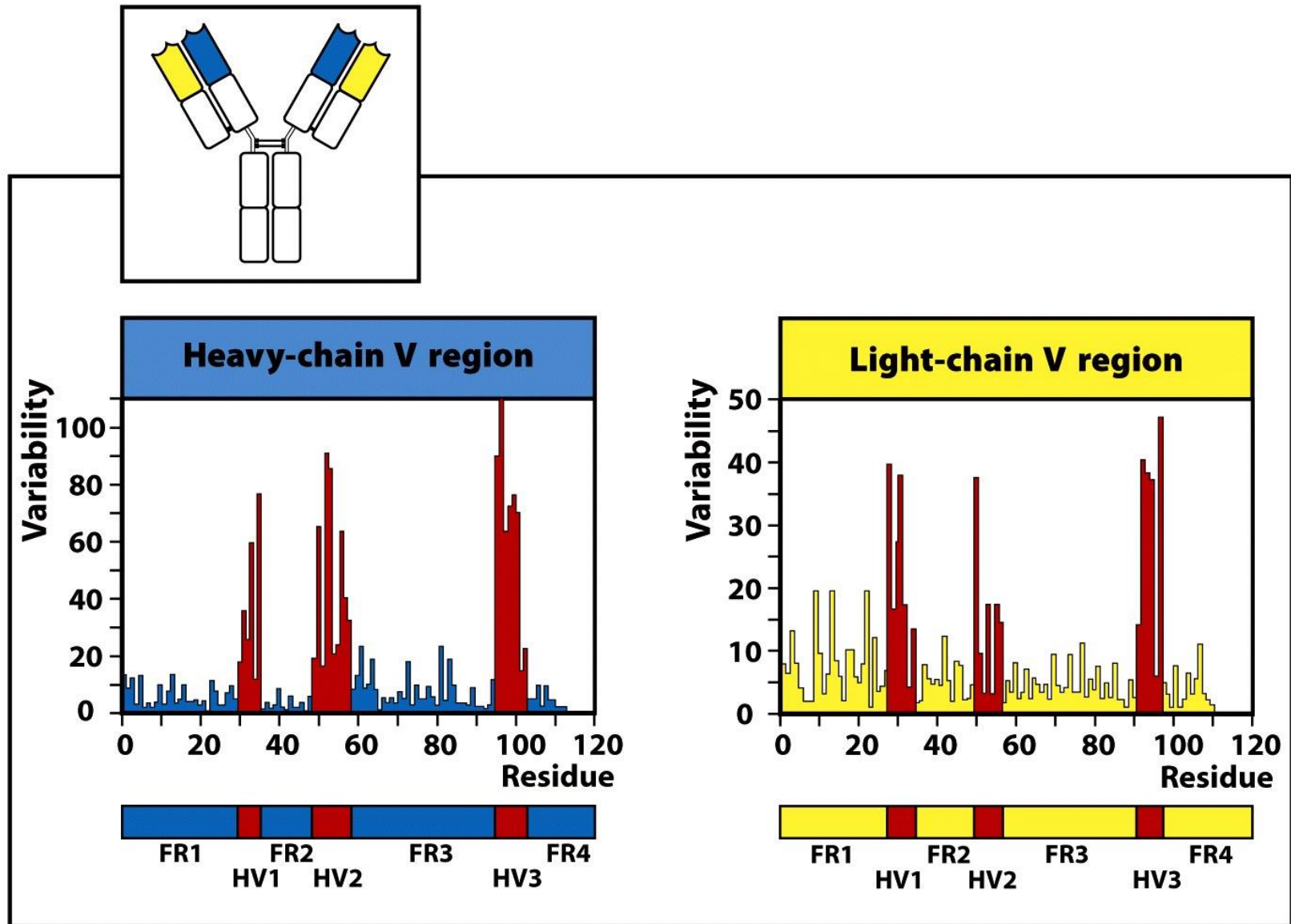

Figure 3-6 Immunobiology, 7ed. (© Garland Science 2008)

1. Υποδοχέας B λεμφοκυττάρων (BCR, αντίσωμα επιφανείας)

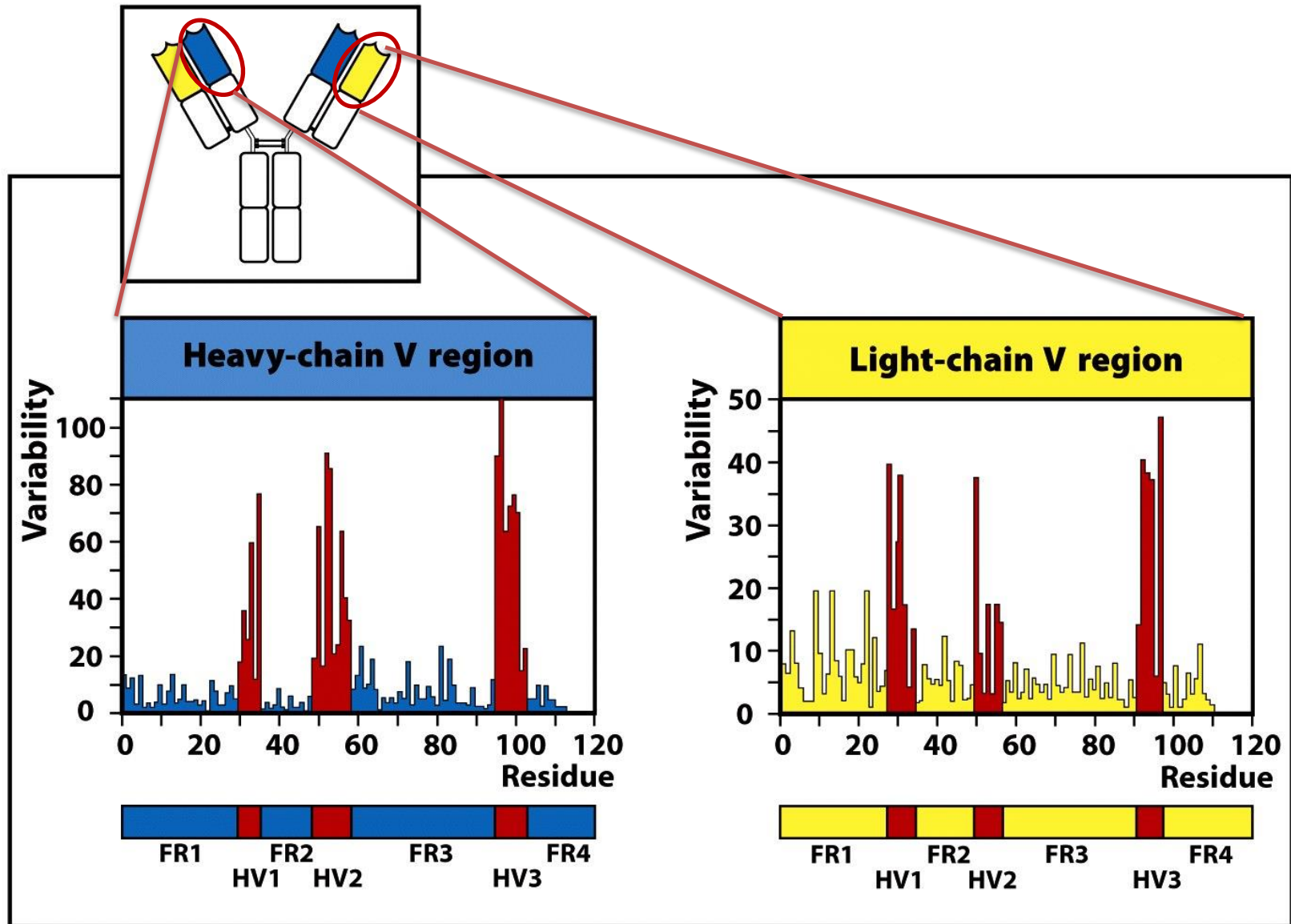

Figure 3-6 Immunobiology, 7ed. (© Garland Science 2008)

Αντιγόνα

Αναγνωρίζονται από τον οργανισμό ως ξένα μόρια και πυροδοτούν μια μη ειδική και μια ειδική ανοσολογική απάντηση

α. **Πλήρες αντιγόνο (antigen) / ανοσογόνο (immunogen)**

β. **Ατελές αντιγόνο (απτίνη, hapten):** χαμηλού μοριακού βάρους μόριο (*βραχύ πεπτίδιο ή φαρμακευτική ουσία*) το οποίο δρα σαν αντιγόνο (αναγνωρίζεται από τον υποδοχέα επιφανείας) αλλά για να δράσει σαν ανοσογόνο θα πρέπει να προσδεθεί σε κάποιο μακρομόριο (carrier, φορέας). Αυτό συμβαίνει γιατί προκειμένου να ενεργοποιηθεί το Β λεμφοκύτταρο θα πρέπει πολλοί κοντινοί BCR να ενεργοποιηθούν ταυτόχρονα (cross-linking)

Αντιγόνα

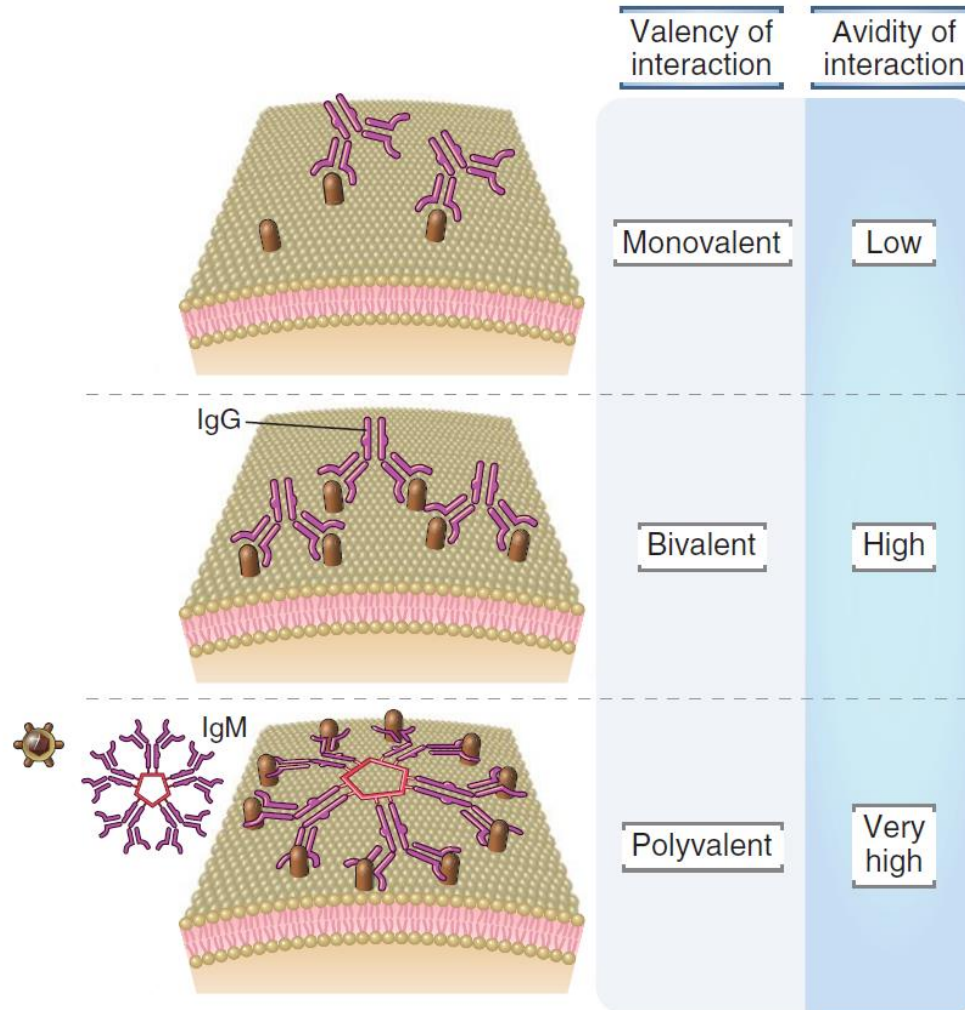

FIGURE 5.14 Valency and avidity of antibody-antigen interactions. Monovalent antigens, or epitopes spaced far apart on cell surfaces, will interact with a single binding site of one antibody molecule. Although the affinity of this interaction may be high, the overall avidity may be relatively low. When repeated determinants on a cell surface are close enough, both the antigen-binding sites of a single IgG molecule can bind, leading to a higher avidity bivalent interaction. The hinge region of the IgG molecule accommodates the shape change needed for simultaneous engagement of both binding sites. IgM molecules have 10 identical antigen-binding sites that can theoretically bind simultaneously with 10 repeating determinants on a cell surface, resulting in a polyvalent, high-avidity interaction.

Αντιγόνα

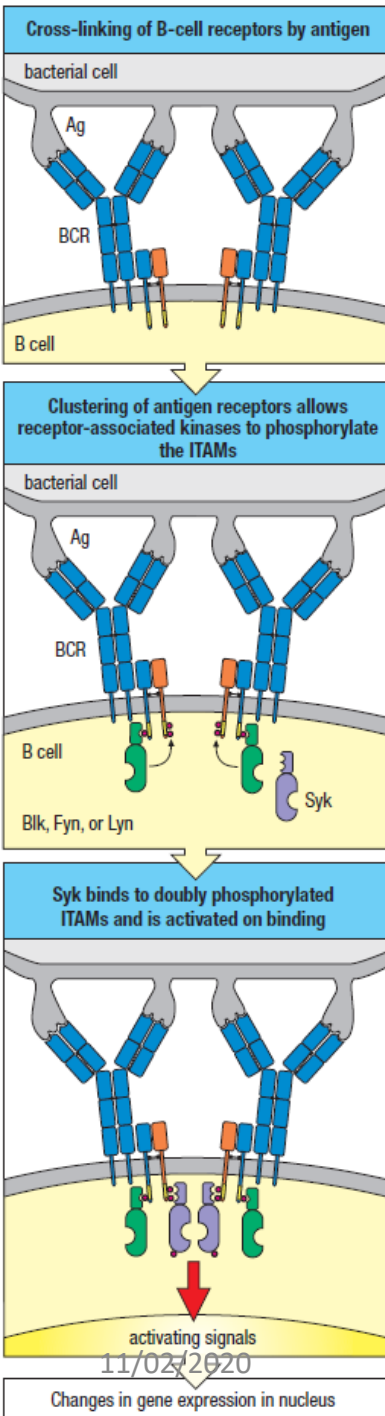
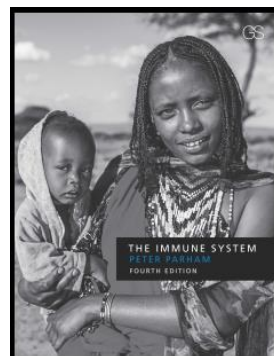

Figure 9.1 Cross-linking of B-cell receptors by antigens initiates a cascade of intracellular signals. Top panel: the B-cell receptor on a mature, naive B cell is composed of monomeric IgM that binds antigen and associated Ig α and Ig β chains, which transduce intracellular signals. The IgM is shown binding repetitive antigens (Ag) on the surface of a bacterium. Center panel: on cross-linking and clustering of the receptors, the receptor-associated tyrosine kinases Blk, Fyn, and Lyn phosphorylate tyrosine residues in the ITAMs of the cytoplasmic tails of Ig α (blue) and Ig β (orange). Bottom panel: subsequently, Syk binds to the phosphorylated ITAMs of the B-cell receptor Ig β chains, which are in close proximity within the cluster and activate each other by transphosphorylation, thus initiating further signaling. Ultimately, the signals are relayed to the nucleus of the B cell, where they induce the changes in gene expression that initiate B-cell activation.



11/02/2020

Changes in gene expression in nucleus

Αντιγόνα

Αναγνωρίζονται από τον οργανισμό ως ξένα μόρια και πυροδοτούν μια μη ειδική και μια ειδική ανοσολογική απάντηση

- α. **Πλήρες αντιγόνο (antigen) / ανοσογόνο (immunogen)**
- β. **Ατελές αντιγόνο (απτίνη, hapten):** χαμηλού μοριακού βάρους μόριο (*βραχύ πεπτίδιο ή φαρμακευτική ουσία*) το οποίο δρα σαν αντιγόνο (αναγνωρίζεται από τον υποδοχέα επιφανείας) αλλά για να δράσει σαν ανοσογόνο θα πρέπει να προσδεθεί σε κάποιο μακρομόριο (carrier, φορέας). Αυτό συμβαίνει γιατί προκειμένου να ενεργοποιηθεί το Β λεμφοκύτταρο θα πρέπει πολλοί κοντινοί BCR να ενεργοποιηθούν ταυτόχρονα (cross-linking)
- γ. **Επίτοπος (epitope) ή αντιγονικός καθοριστής (determinant):** περιοχή στο αντιγόνο που συνδέεται με το αντίσωμα (πολύ μικρή περιοχή, 5-7 αμινοξέα)

1. Υποδοχέας Β λεμφοκυττάρων (BCR, αντίσωμα επιφανείας)

Αντιγονικοί επίτοποι

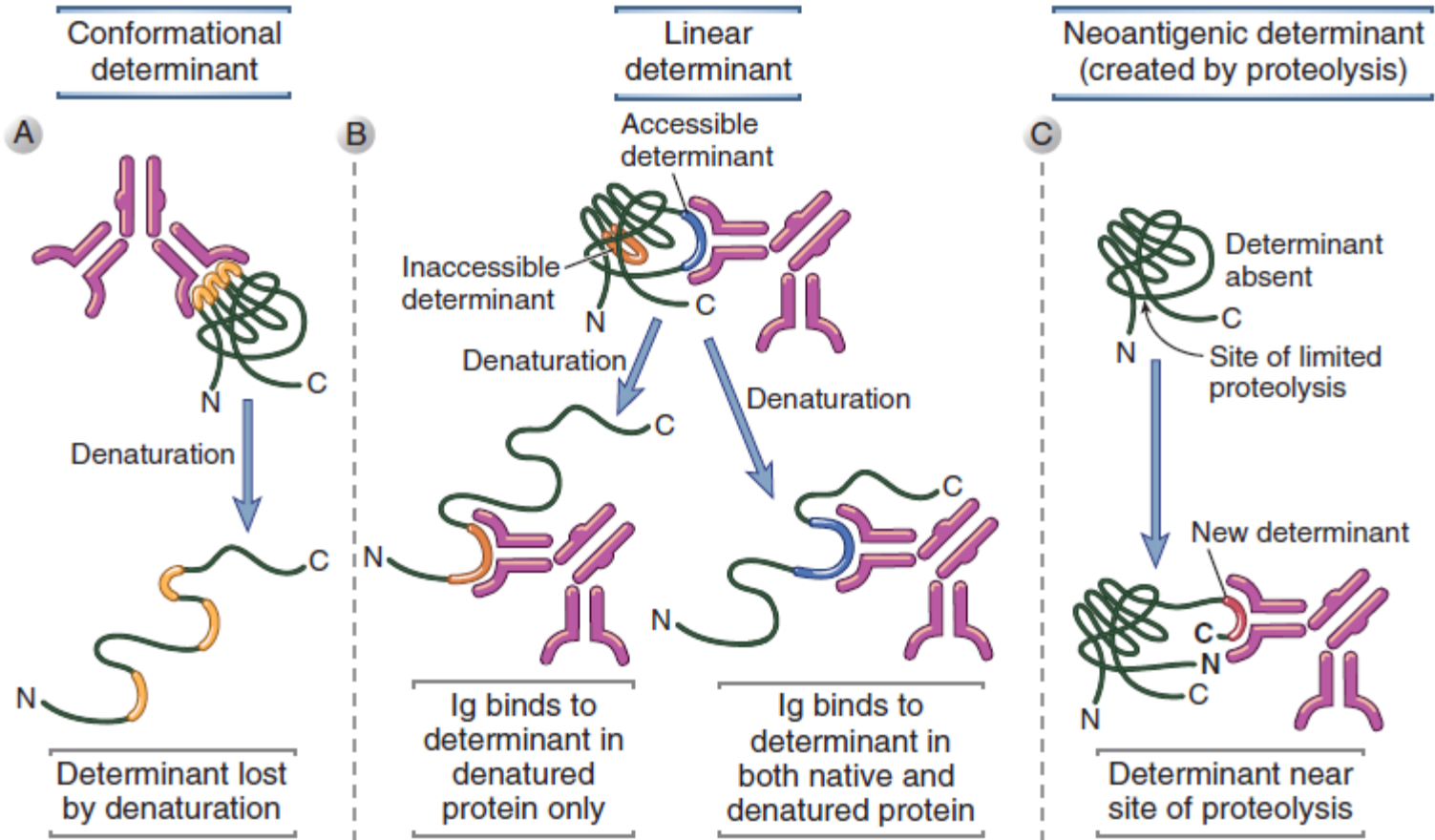
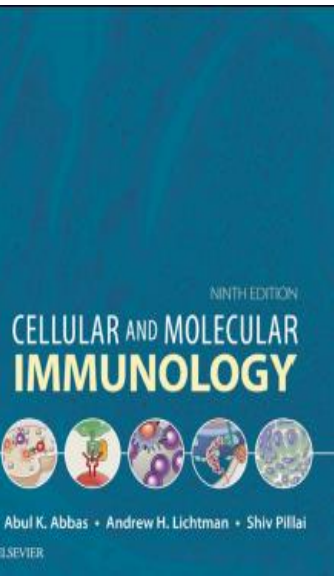

FIGURE 5.13 The nature of antigenic determinants. Antigenic determinants (shown in orange, red, and blue) may depend on protein folding (conformation) as well as on primary structure. Some determinants are accessible in native proteins and are lost on denaturation (A), whereas others are exposed only on protein unfolding (B). Neodeterminants arise from postsynthetic modifications such as peptide bond cleavage (C).



1. Υποδοχέας Β λεμφοκυττάρων (BCR, αντίσωμα επιφανείας)

Αναγνωρίζει εξωκυττάρια αντιγόνα

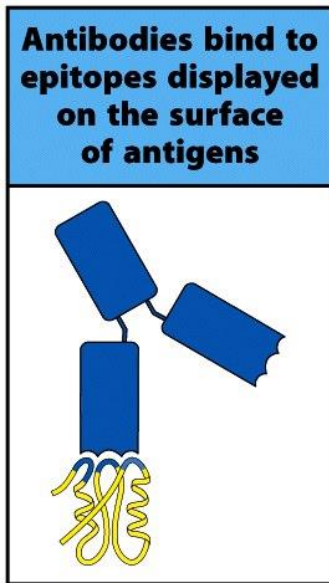

Figure 1-16 Immunobiology, 7ed. (© Garland Science 2008)

2. Υποδοχέας T λεμφοκυττάρων (TCR)

Αναγνωρίζει ενδοκυττάρια αντιγόνα με την μορφή σπασμένων μικρών πεπτιδίων τα οποία παρουσιάζονται στην επιφάνεια των κυττάρων με την βοήθεια των αντιγόνων ιστοσυμβατότητας (MHC μόρια)

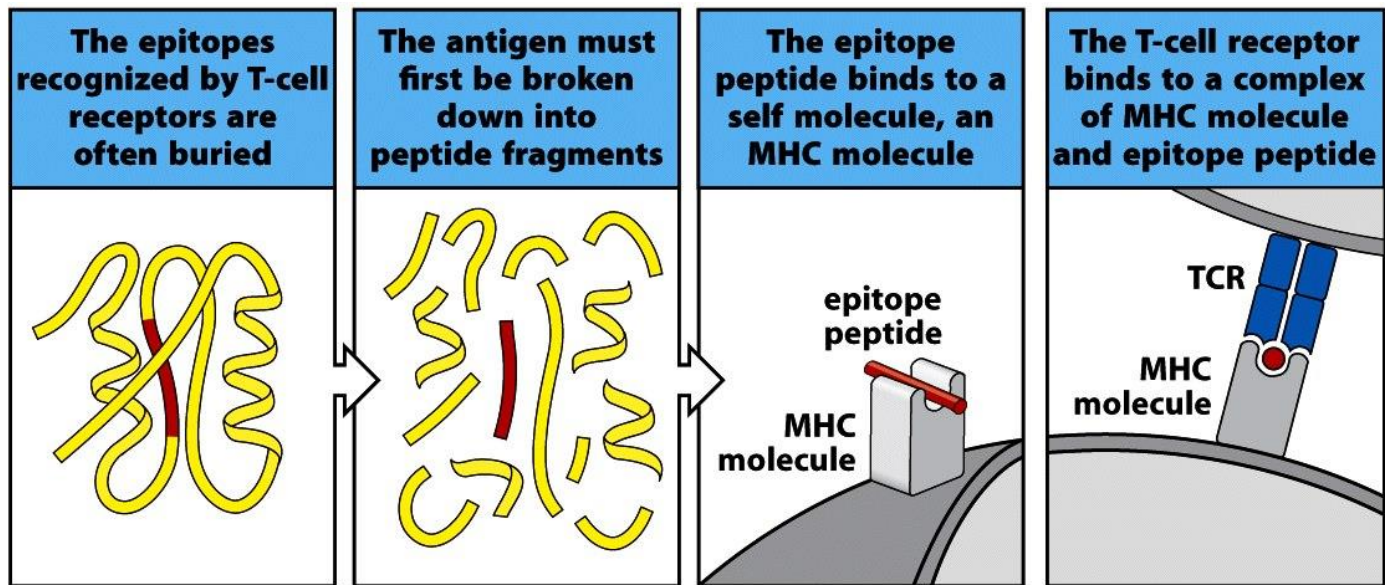

Figure 1-16 Immunobiology, 7ed. (© Garland Science 2008)

2. Υποδοχέας T λεμφοκυττάρων (TCR)

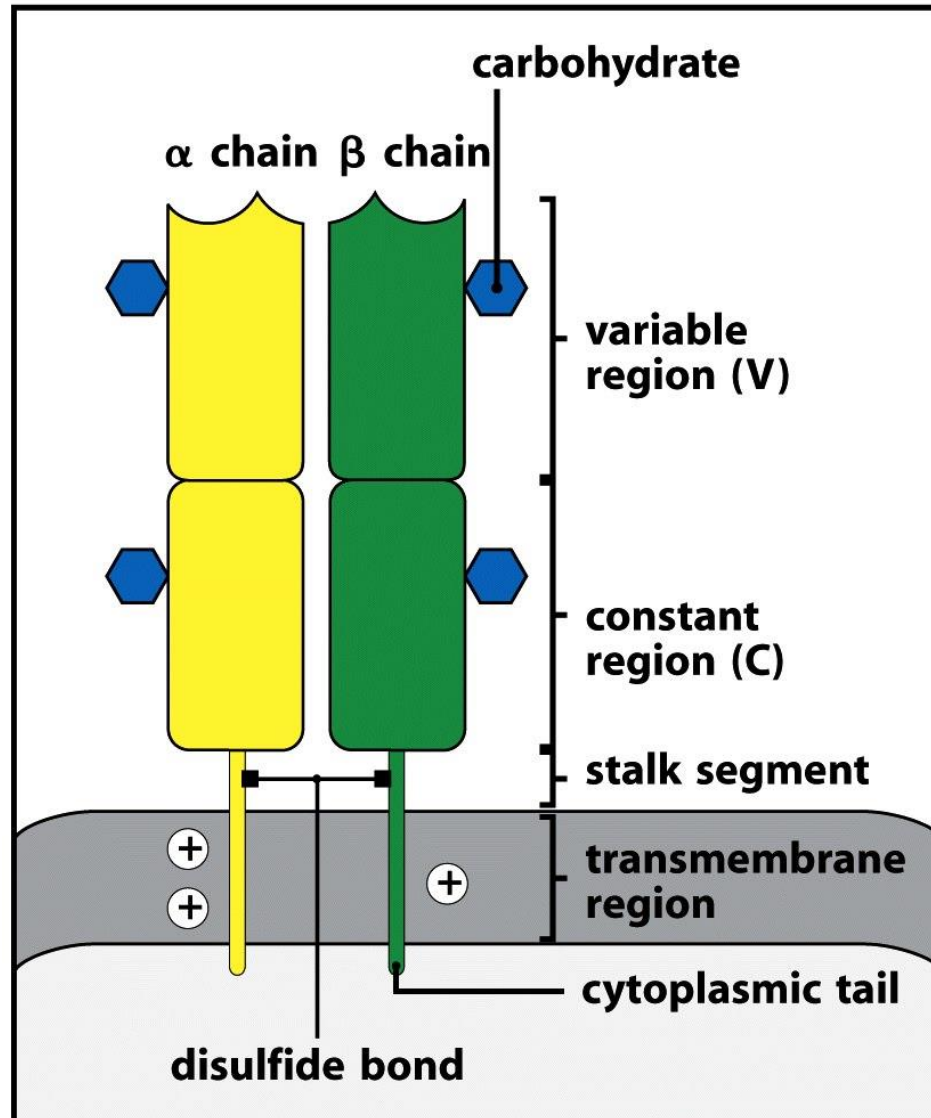
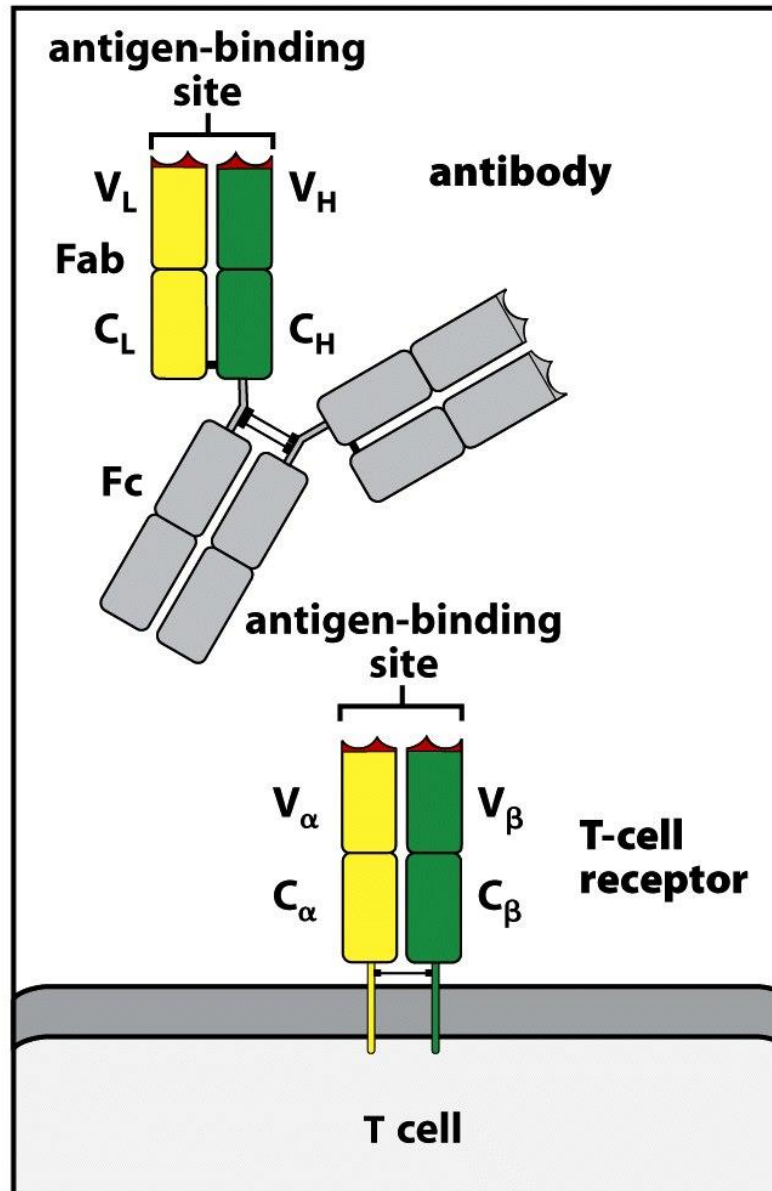

Figure 3-12 Immunobiology, 7ed. (© Garland Science 2008)

Σύγκριση Β και Τ κυτταρικού υποδοχέα



Αντιγονική παρουσίαση στον T κυτταρικό υποδοχέα

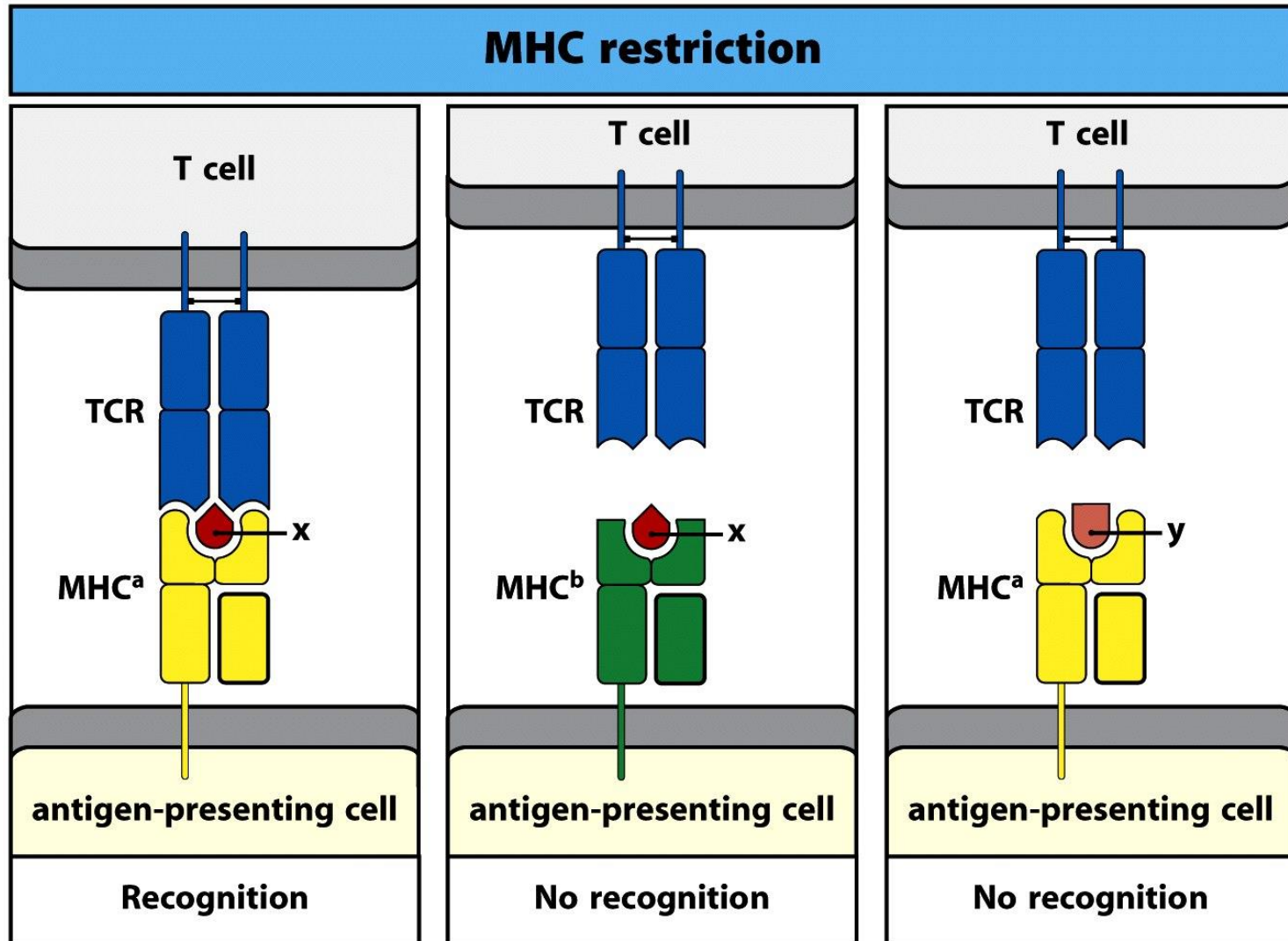

Figure 5-20 Immunobiology, 7ed. (© Garland Science 2008)

Αντιγονική παρουσίαση στον T κυτταρικό υποδοχέα
μέσω των μορίων του μείζονος συμπλέγματος ιστοσυμβατότητας
(=αντιγόνα ιστοσυμβατότητας)

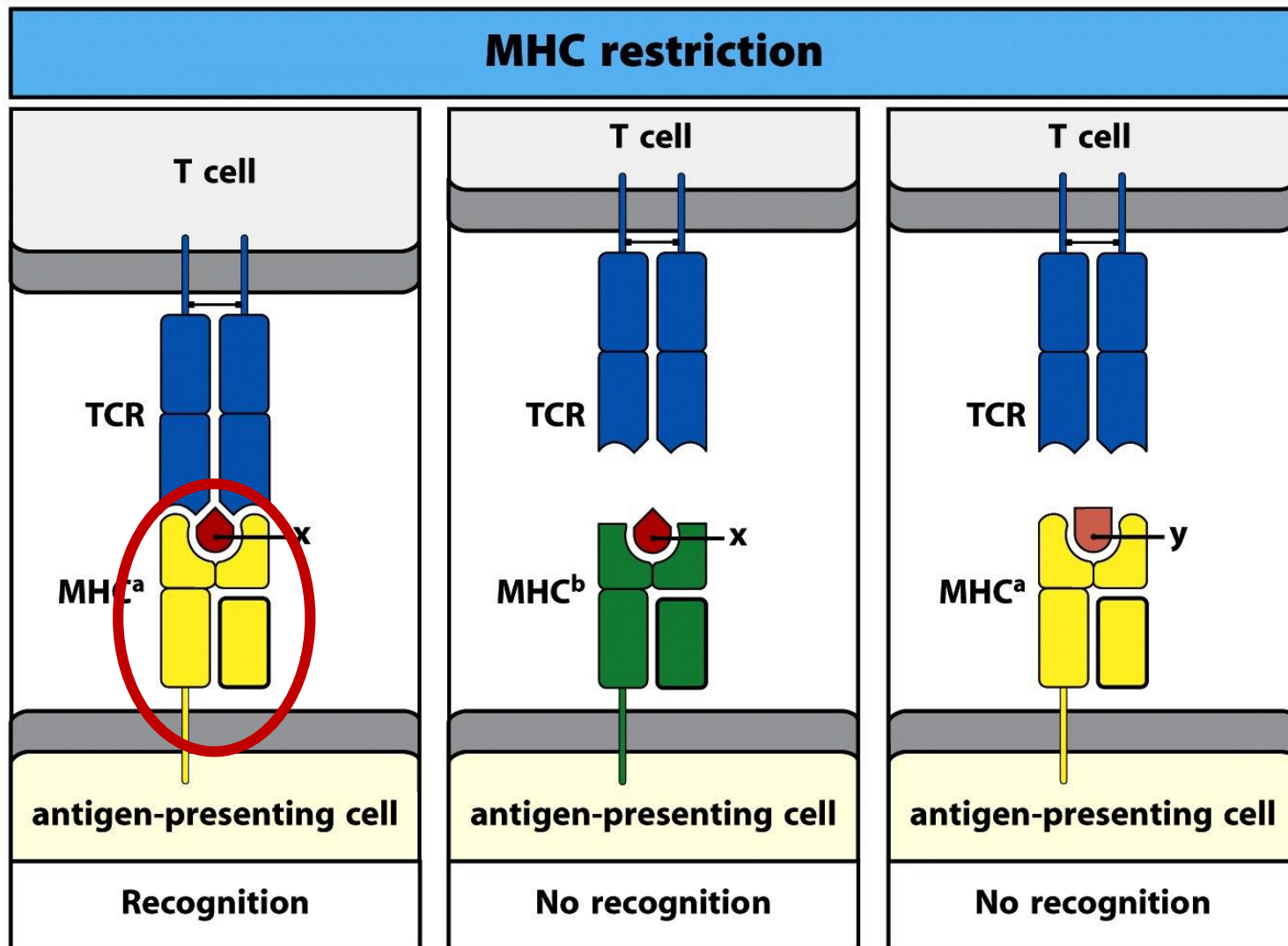

Figure 5-20 Immunobiology, 7ed. (© Garland Science 2008)

Μόρια Ιστοσυμβατότητας

Ανοσορυθμιστικά αντιγόνα κυτταρικής επιφάνειας

Συνώνυμα

- Αντιγόνα μείζονος συμπλέγματος ιστοσυμβατότητας (MHC)
- Ανθρώπινα λευκυτταρικά αντιγόνα (HLA)
- Αντιγόνα μεταμοσχεύσεων

Μόρια Ιστοσυμβατότητας

- **Βασικοί συντελεστές της ειδικής κυτταρικής ανοσο-αντίδρασης μέσω της παρουσίασης αντιγονικών πεπτιδίων ως σύμπλεγμα στα T λεμφοκύτταρα**
- **Ιδιαίτερα πολυμορφικό σύστημα** λόγω μεγάλου αριθμού εναλλακτικών γονιδιακών αλληλιών, ο συνδυασμός των οποίων καθορίζει την **ιστική ταυτότητα** κάθε ατόμου
- **Ιδιαίτερα ανοσογόνα**, υπεύθυνα για την απόρριψη αλλομοσχευμάτων

Ταξινόμηση των μορίων HLA

- **HLA Τάξης I** : υπάρχουν σε όλα τα κύτταρα. Παρουσιάζουν ξένες προς τον οργανισμό πρωτεΐνες ενδο-κυττάριας προέλευσης (παθολογικές πρωτεΐνες, ιικές πρωτεΐνες και πρωτεΐνες καρκινικών κυττάρων)
- **HLA Τάξης II** : υπάρχουν κυρίως στα **αντιγονοπαρουσιαστικά κύτταρα (antigen presenting cells)** δηλ. στα μακροφάγα, στα κύτταρα Langerhans του δέρματος, στα διαπλεκόμενα και δενδριτικά κύτταρα του λεμφικού ιστού και στα B λεμφοκύτταρα. Παρουσιάζουν κλάσματα πεπτιδίων (προϊόντα φαγοκυττάρωσης εξωγενών πρωτεϊνών π.χ. βακτηριακών)
- **HLA Τάξης III** : συστατικά συμπληρώματος, κυτταροκίνες (TNF α και β), πρωτεΐνες οξείας φάσης.

Δύο τύποι αντιγόνων ιστοσυμβατότητας:

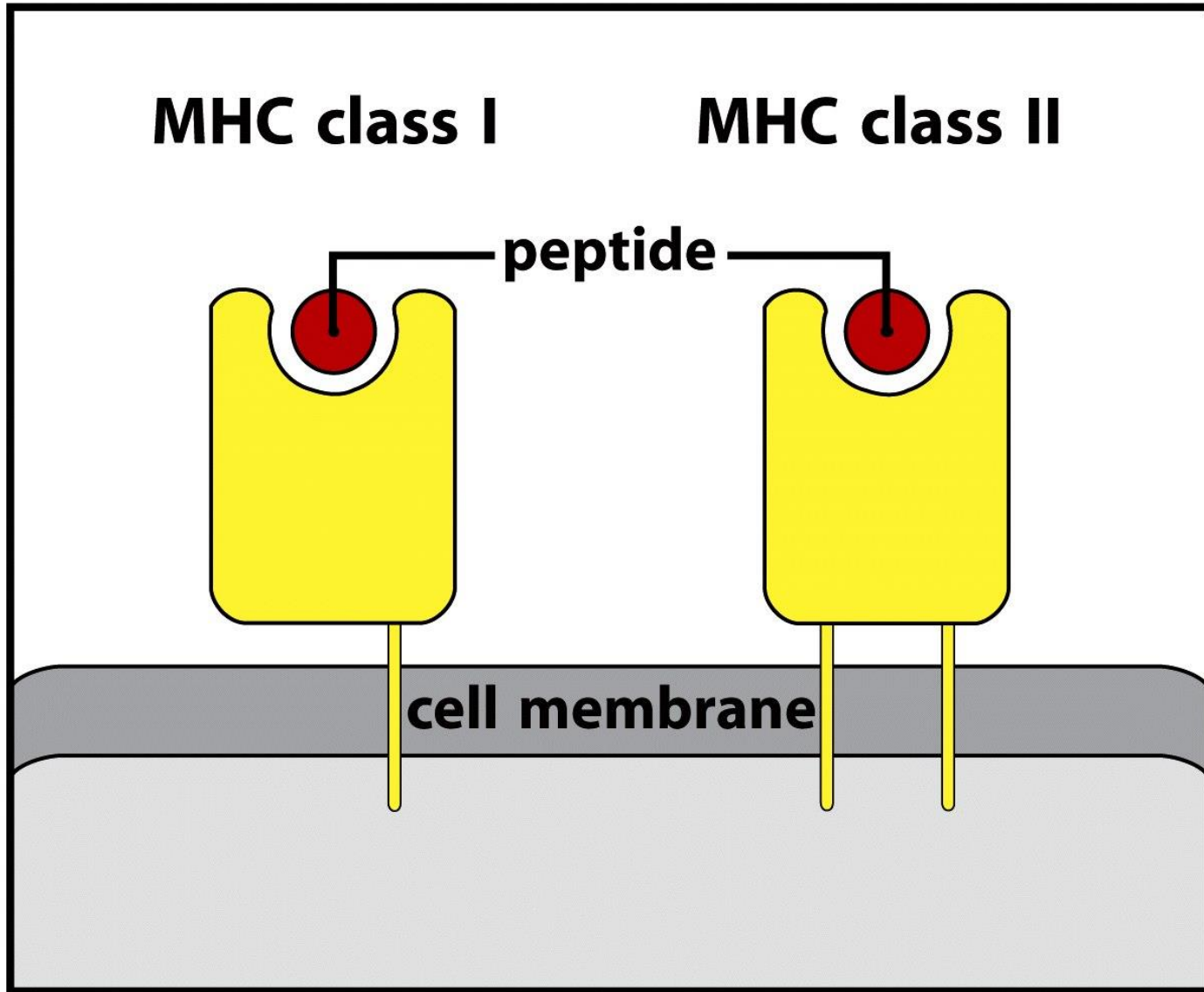

Δύο τύποι αντιγόνων ιστοσυμβατότητας:

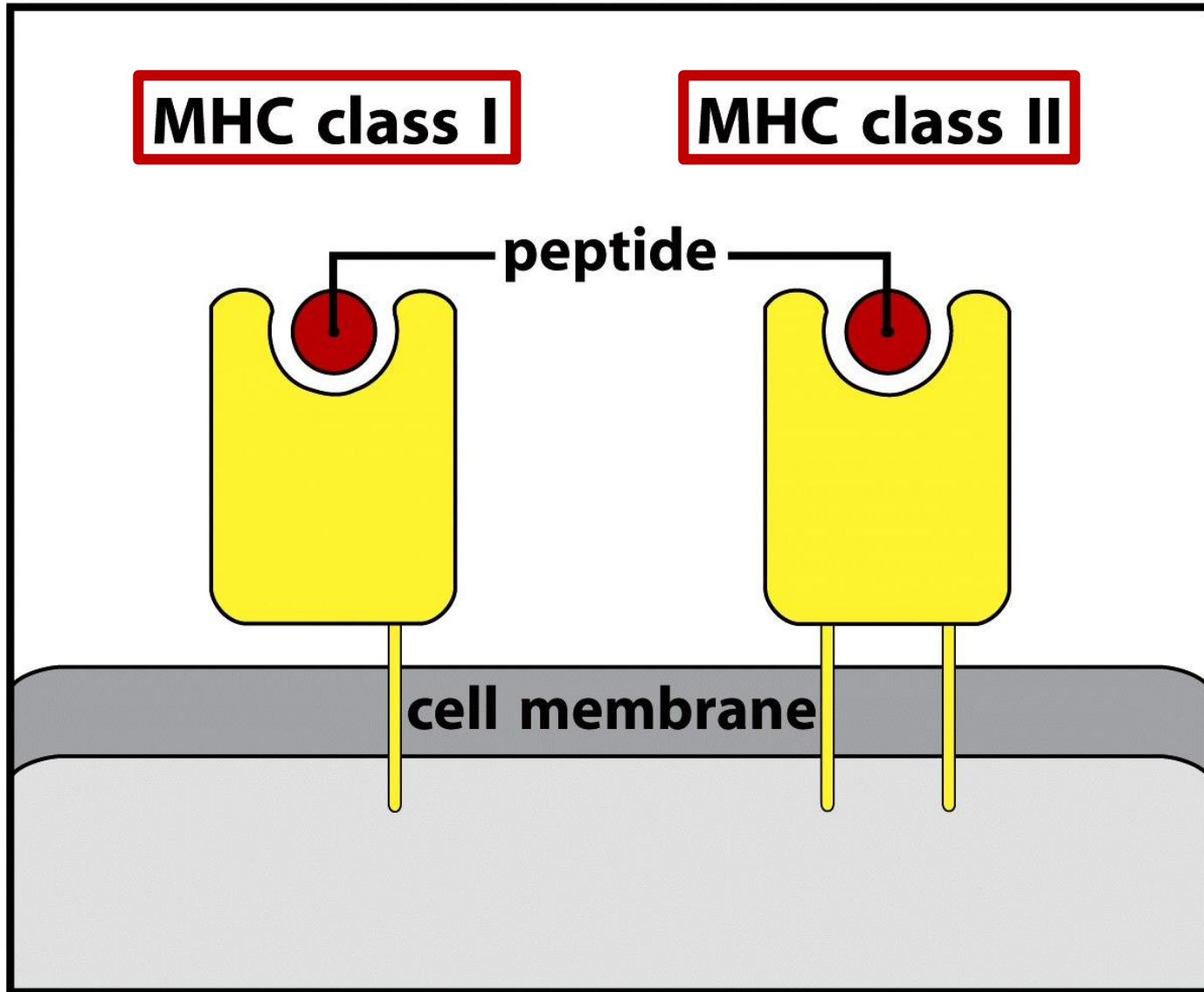

MHC class I

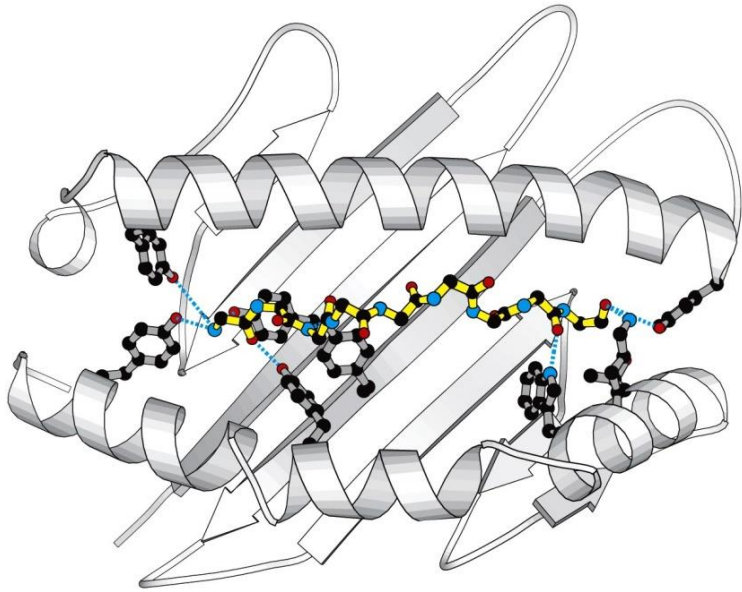
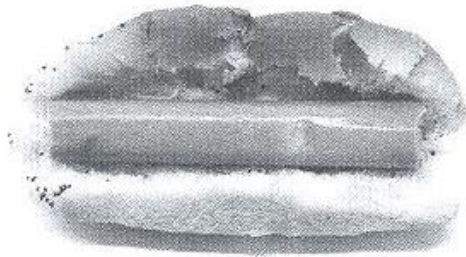

Figure 3-18 Immunobiology, 7ed. (© Garland Science 2008)



MHC class II

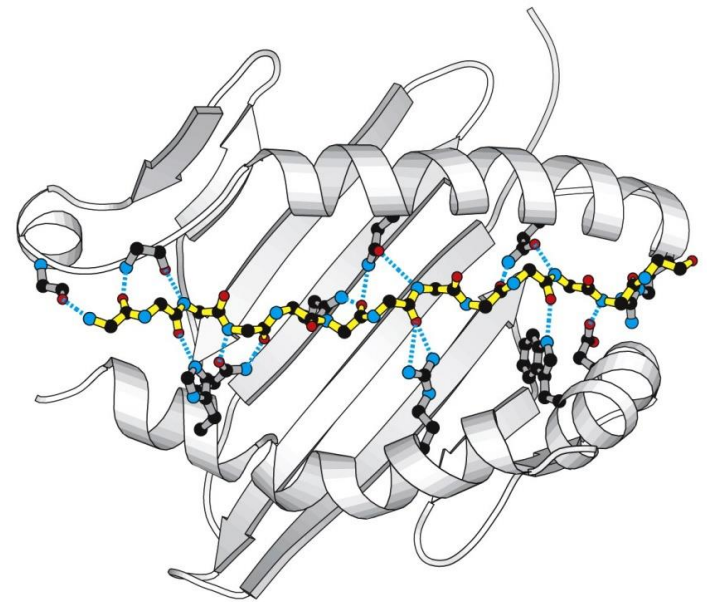
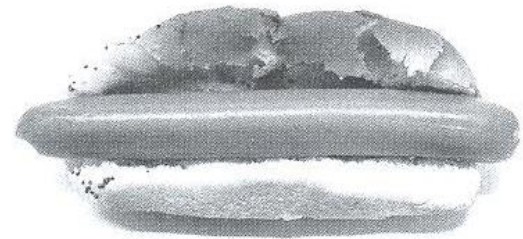

Figure 3-20 Immunobiology, 7ed. (© Garland Science 2008)



MHC class I

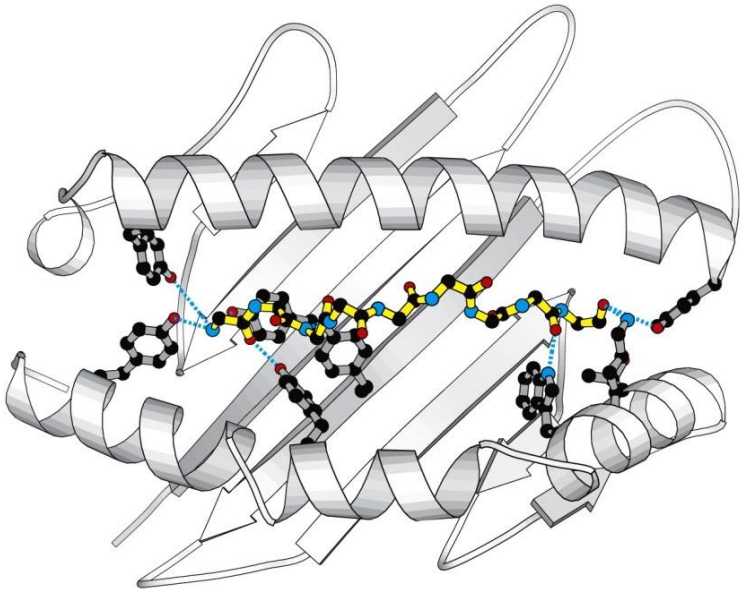

Figure 3-18 Immunobiology, 7ed. (© Garland Science 2008)

Ενδογενή αντιγόνα



CD8+ κυτταροτοξικά
T λεμφοκύτταρα

MHC class II

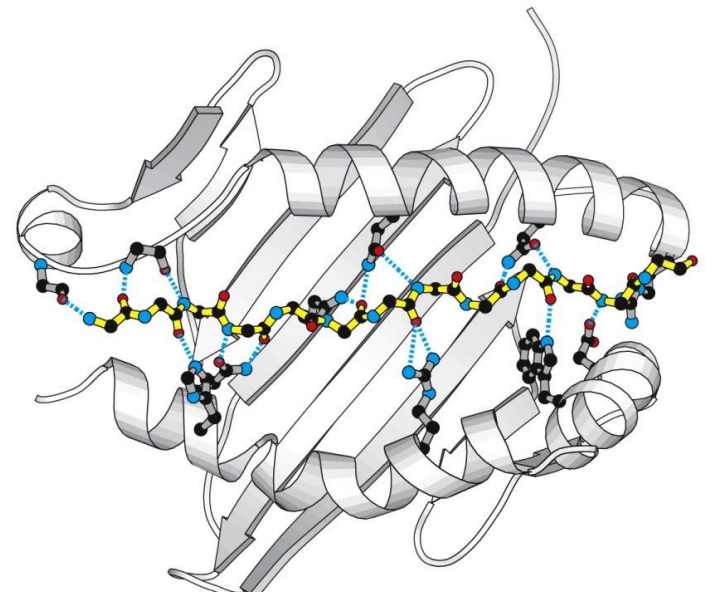

Figure 3-20 Immunobiology, 7ed. (© Garland Science 2008)

Εξωγενή αντιγόνα



CD4+ βοηθητικά
T λεμφοκύτταρα

Αντιγονική παρουσίαση ενδογενών (ικών) αντιγόνων στα CD8+ T λεμφοκύτταρα

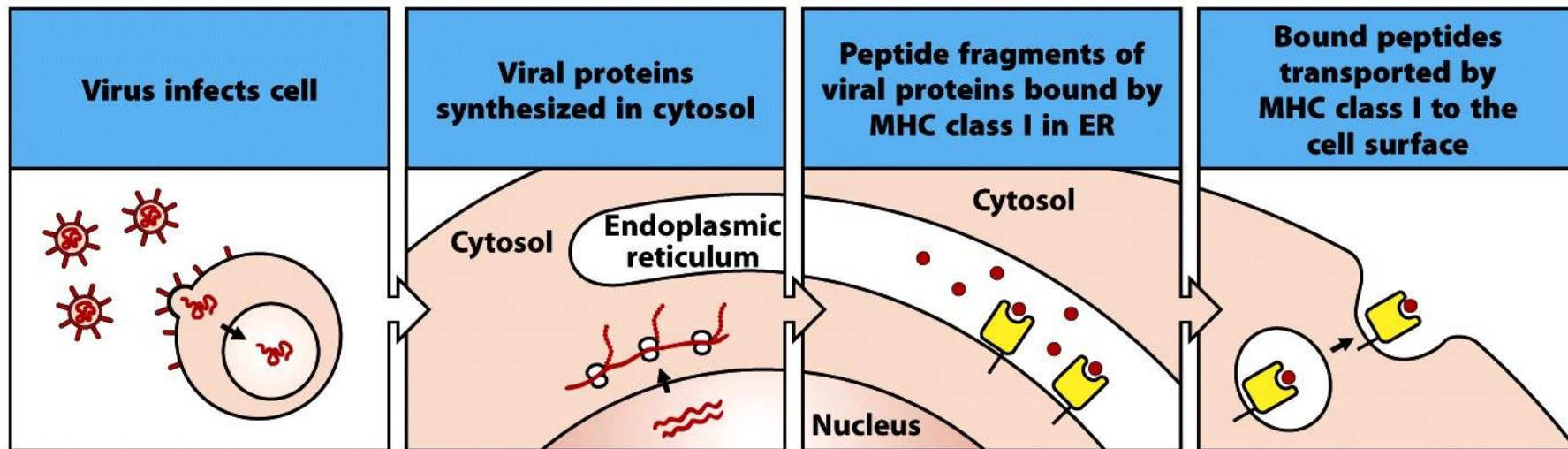

Figure 1-30 Immunobiology, 7ed. (© Garland Science 2008)

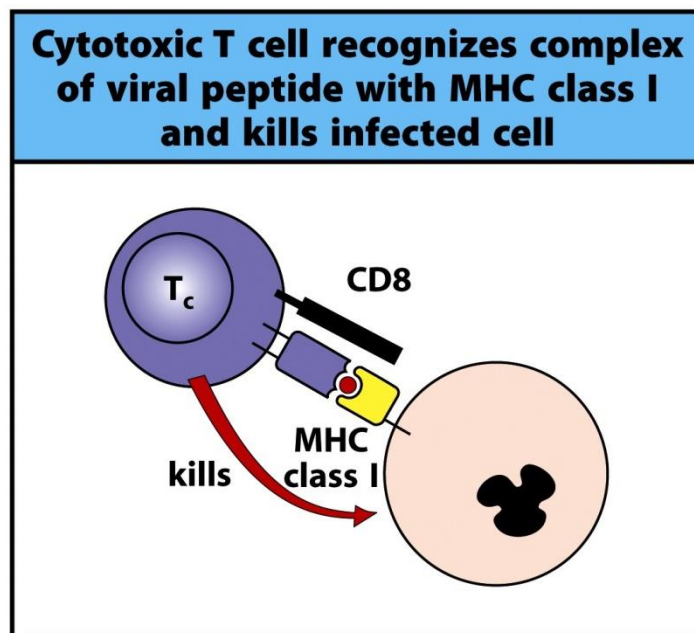
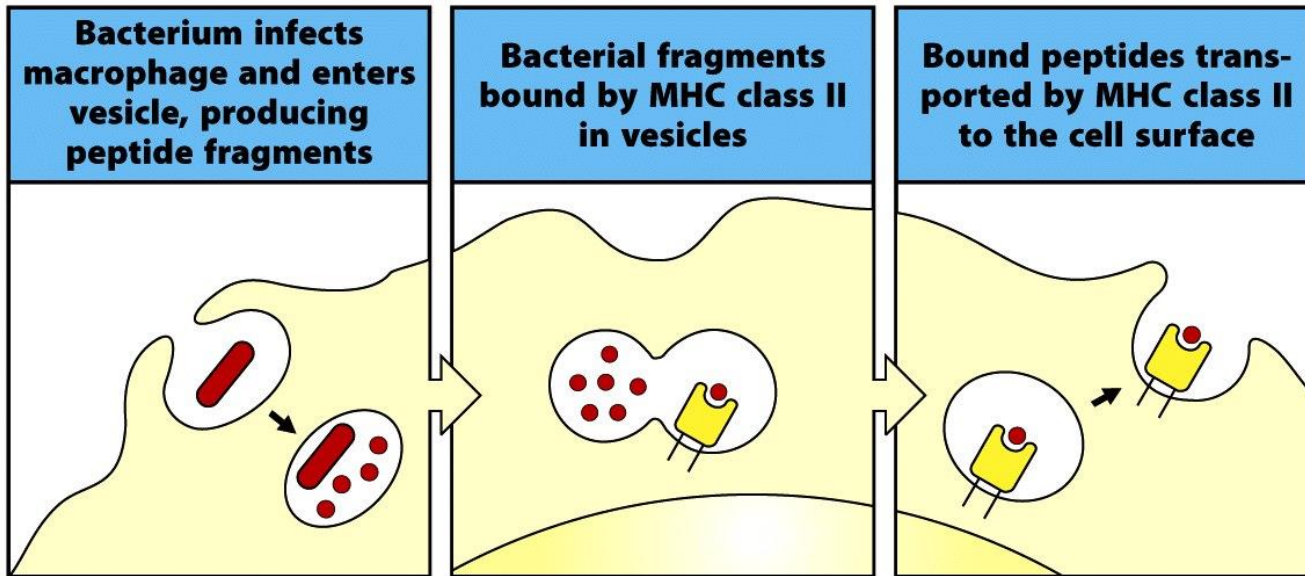

Figure 1-32 Immunobiology, 7ed. (© Garland Science 2008)

Αντιγονική παρουσίαση εξωγενών αντιγόνων στα CD4+ T λεμφοκύτταρα

Macrophage,
Mφ



B lymphocyte

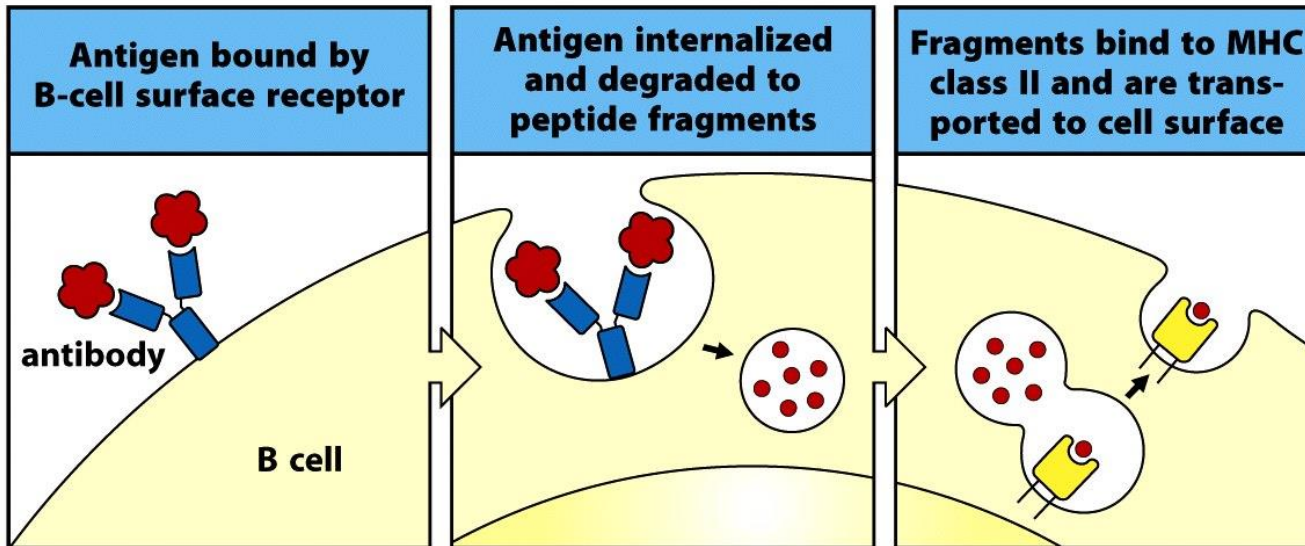

Αντιγονική παρουσίαση εξωγενών αντιγόνων στα CD4+ T λεμφοκύτταρα

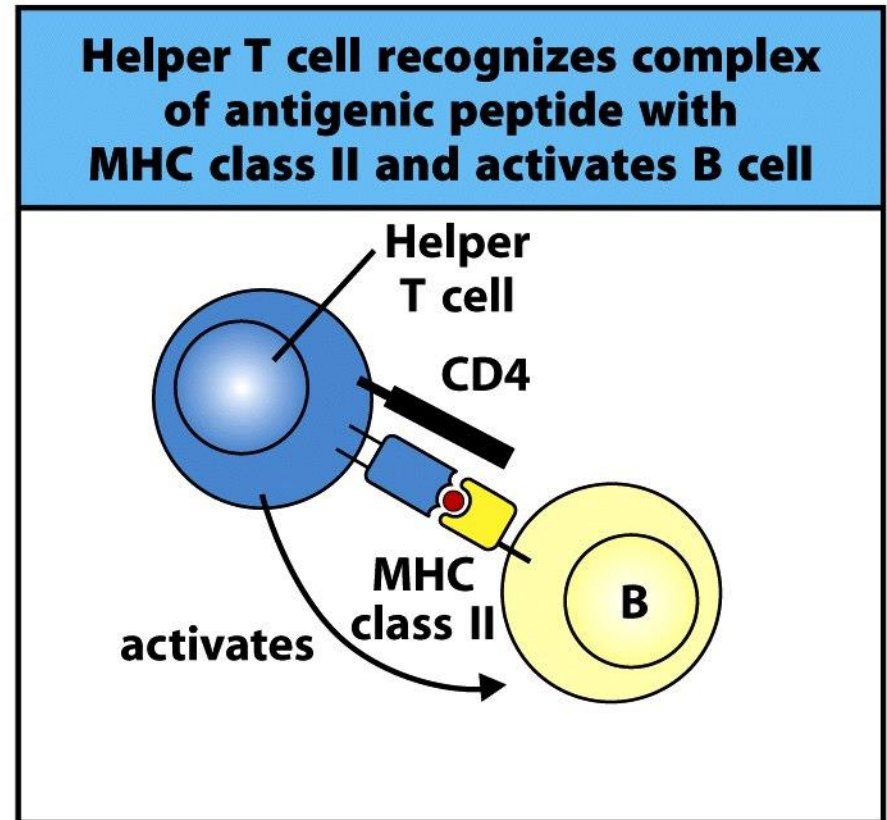
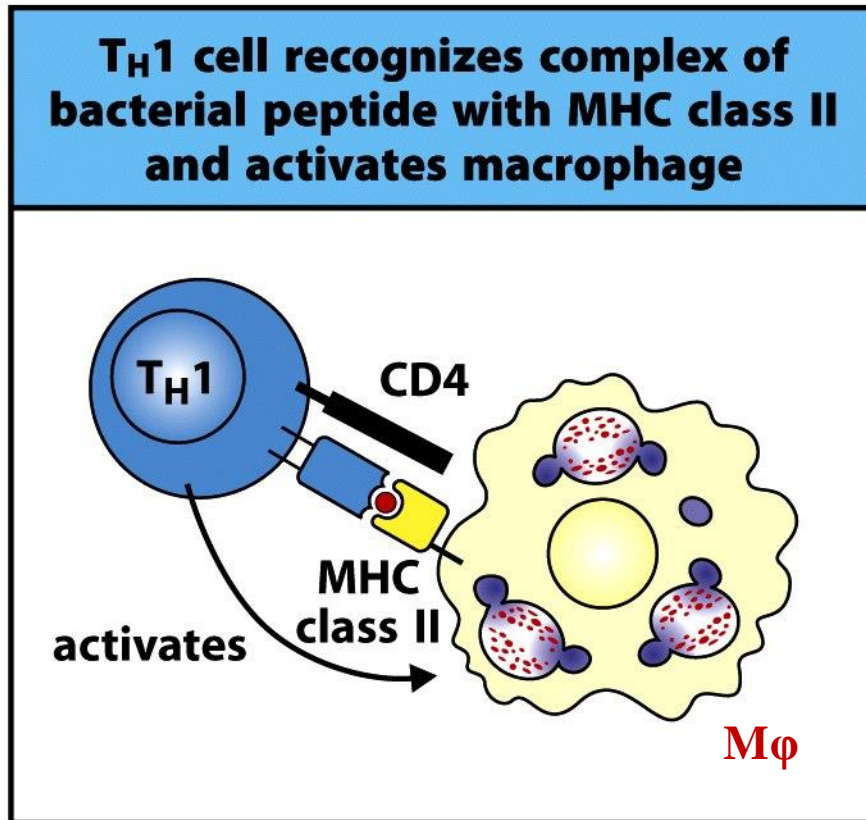

Figure 1-33 Immunobiology, 7ed. (© Garland Science 2008)

Για την ενεργοποίηση των Τ λεμφοκυττάρων είναι απαραίτητα **συνδιεγερτικά σήματα**

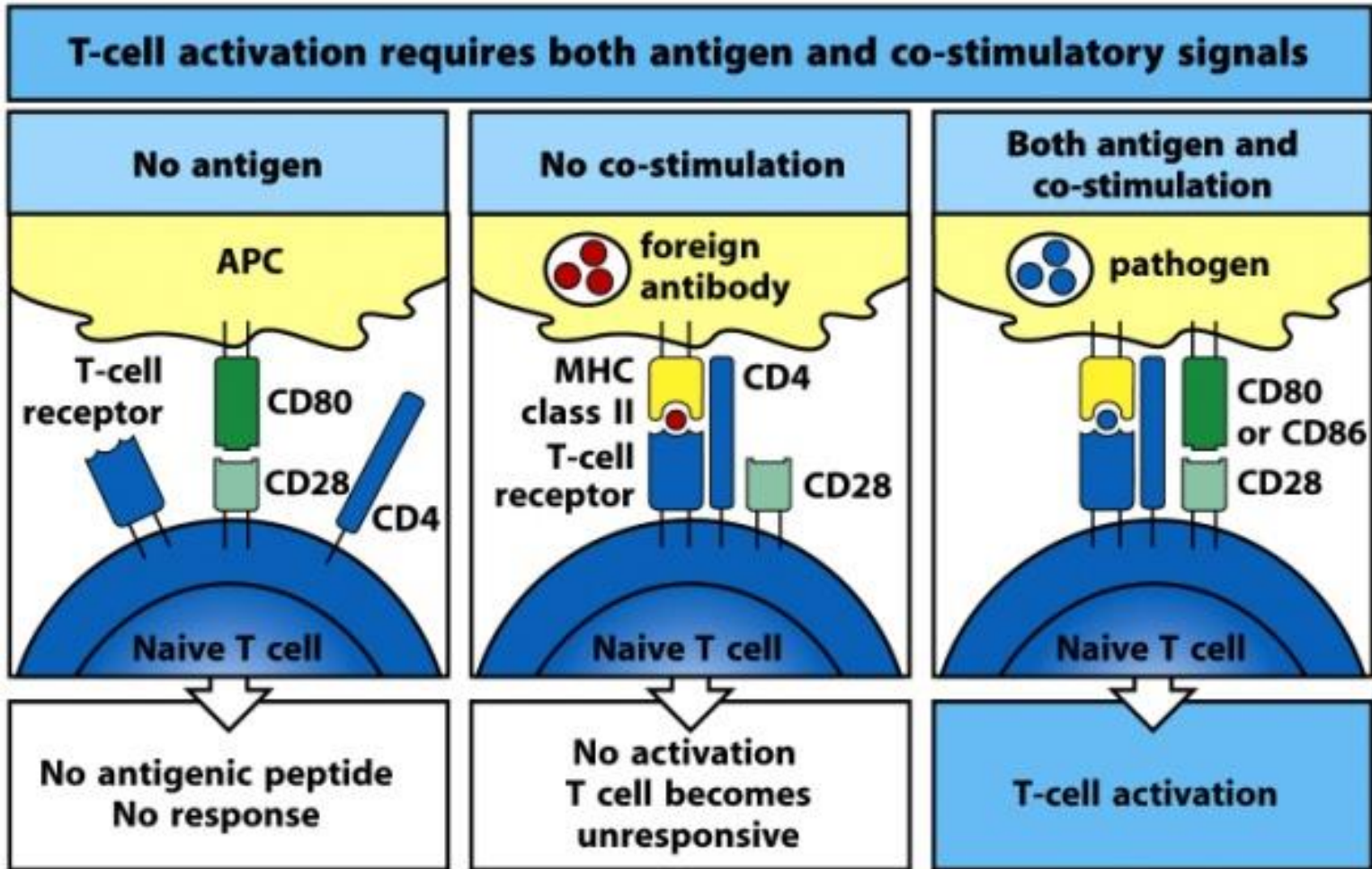

Figure 2-23 Immunobiology, 7ed. (© Garland Science 2008)

CTLA-4 binds B7 more avidly than does CD28 and delivers inhibitory signals to activated T cells

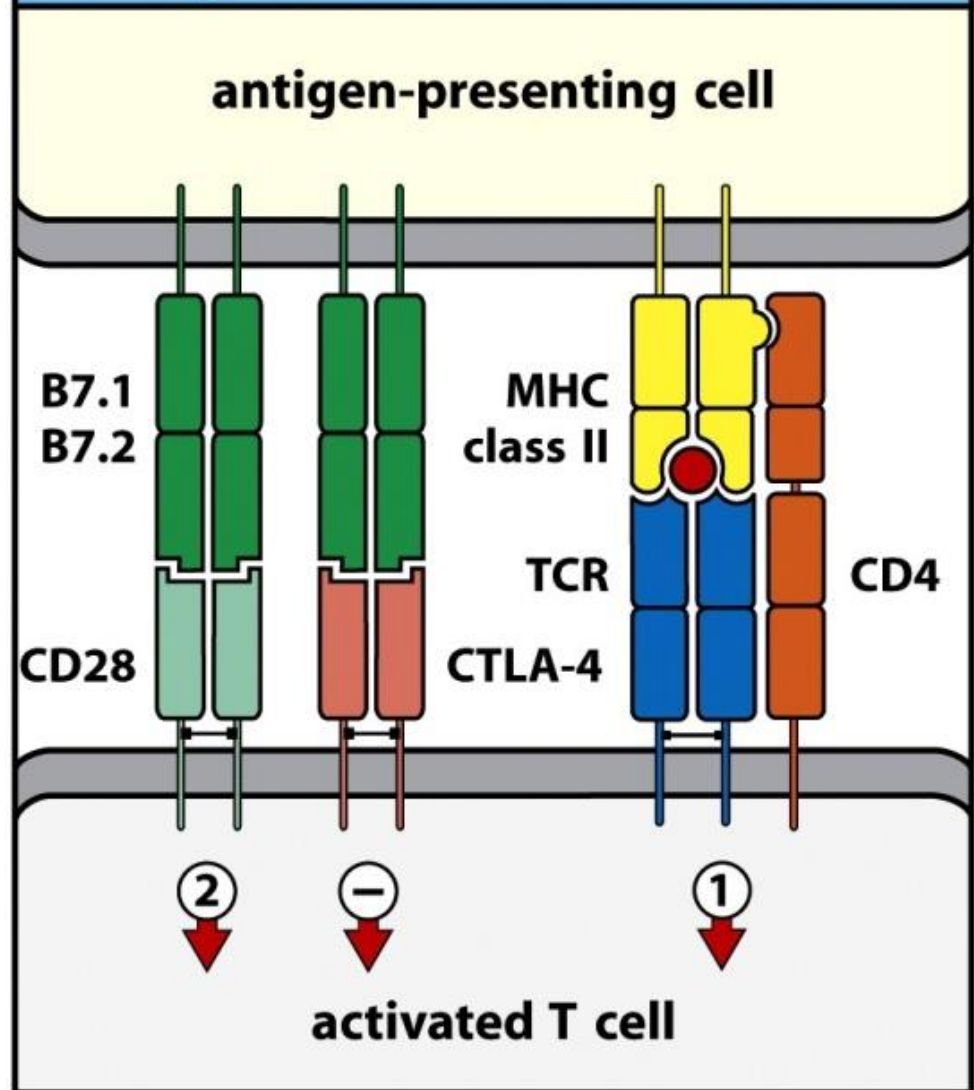
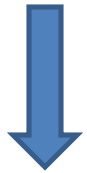

Figure 8-22 Immunobiology, 7ed. (© Garland Science 2008)

Τα ενεργοποιημένα Τ λεμφοκύτταρα εκφράζουν στην επιφάνειά τους την πρωτεΐνη CTLA-4, η οποία δεσμεύει τα μόρια B7.1, 2 που εκφράζονται στην επιφάνεια των αντιγονοπαρουσιαστικών κυττάρων και στέλνει ανασταλτικό ενδοκυττάριο σήμα για παύση της κατάστασης ενεργοποίησης.



Brake

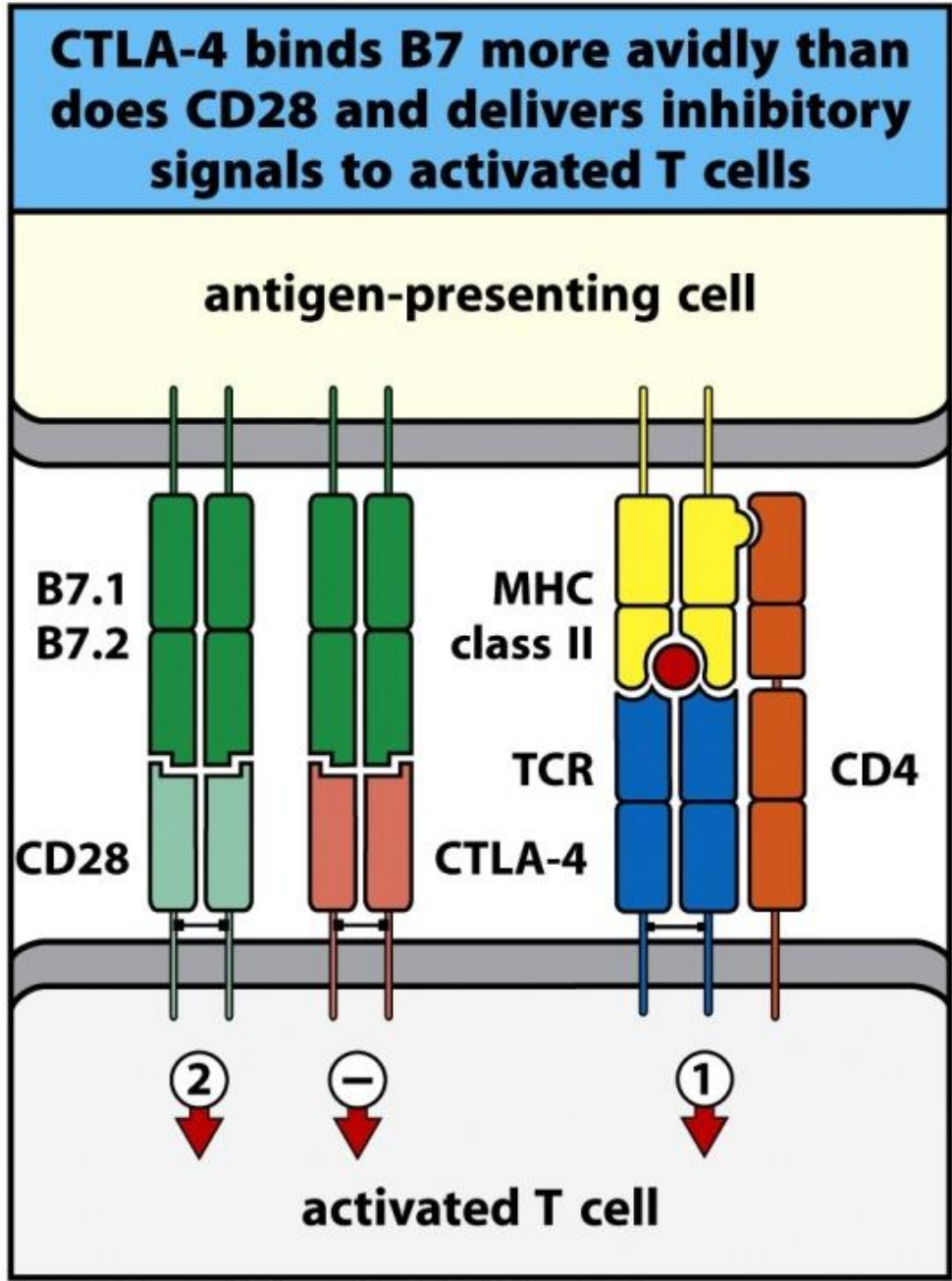

Figure 8-22 Immunobiology, 7ed. (© Garland Science 2008)

Fundamental Mechanisms of Immune Checkpoint Blockade Therapy



Spencer C. Wei¹, Colm R. Duffy¹, and James P. Allison^{1,2}

Fundamental Mechanisms of Immune Checkpoint Blockade Therapy

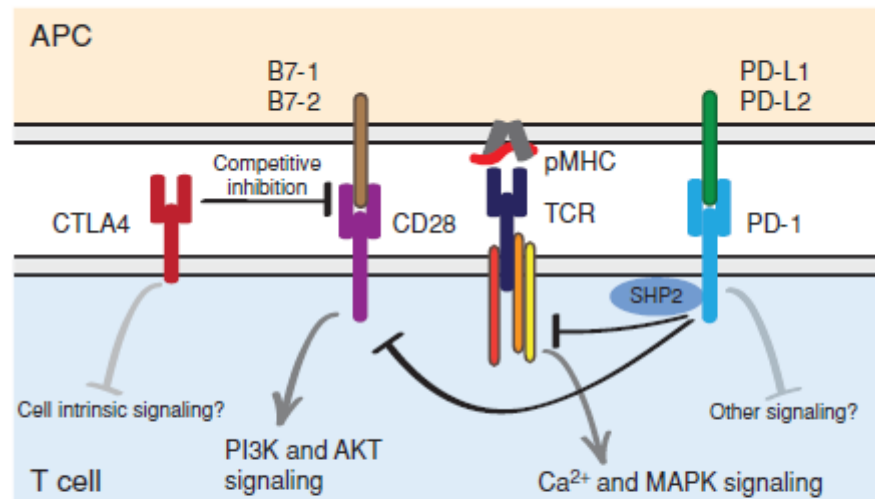

Figure 1. Molecular mechanisms of CTLA4 and PD-1 attenuation of T-cell activation. Schematic of the molecular interactions and downstream signaling induced by ligation of CTLA4 and PD-1 by their respective ligands. The possibility of additional downstream cell-intrinsic signaling mechanisms is highlighted for both CTLA4 and PD-1.

Το ρεπερτόριο των αντισωμάτων και των T κυτταρικών υποδοχέων

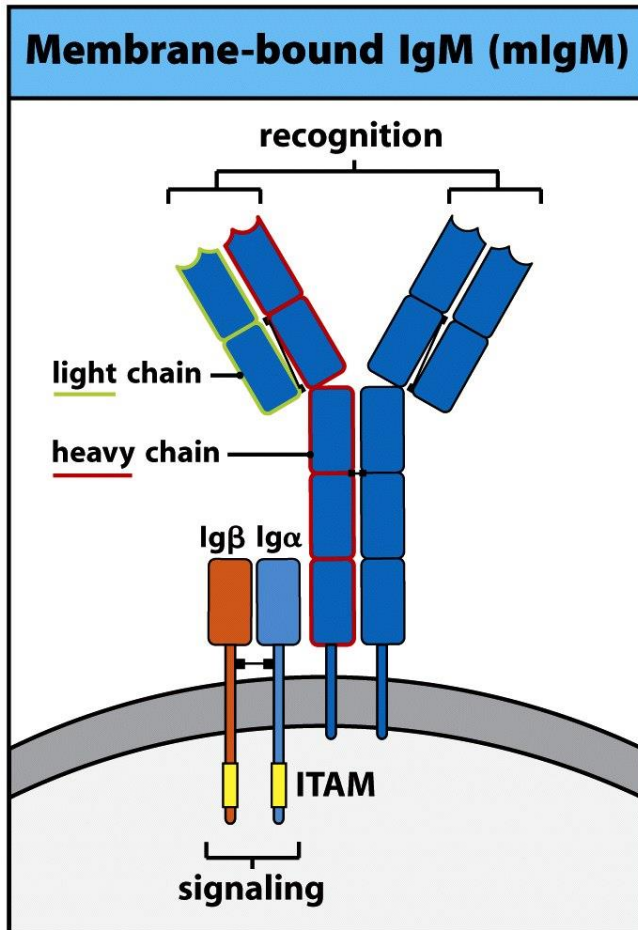

Figure 6-9 Immunobiology, 7ed. (© Garland Science 2008)

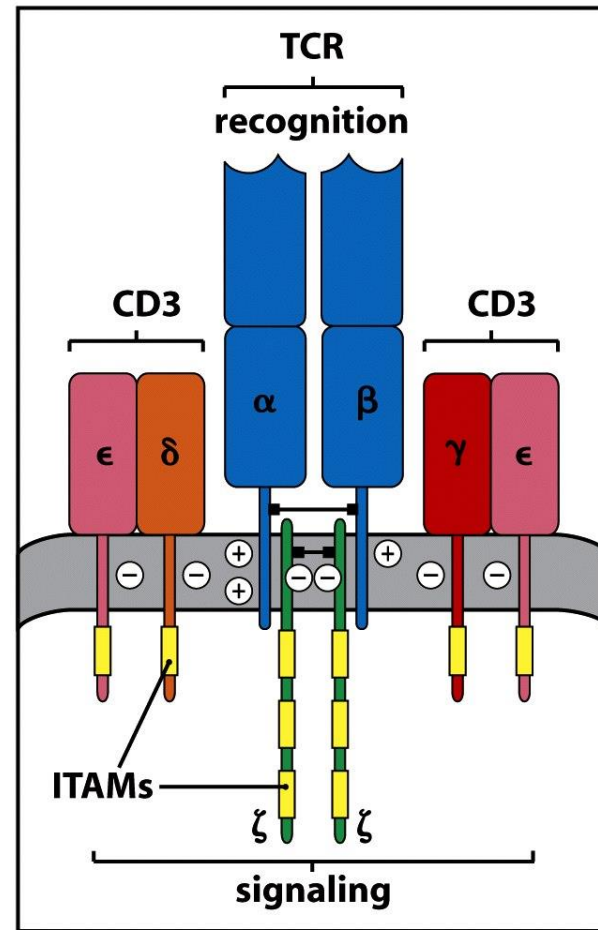

Figure 6-10 Immunobiology, 7ed. (© Garland Science 2008)

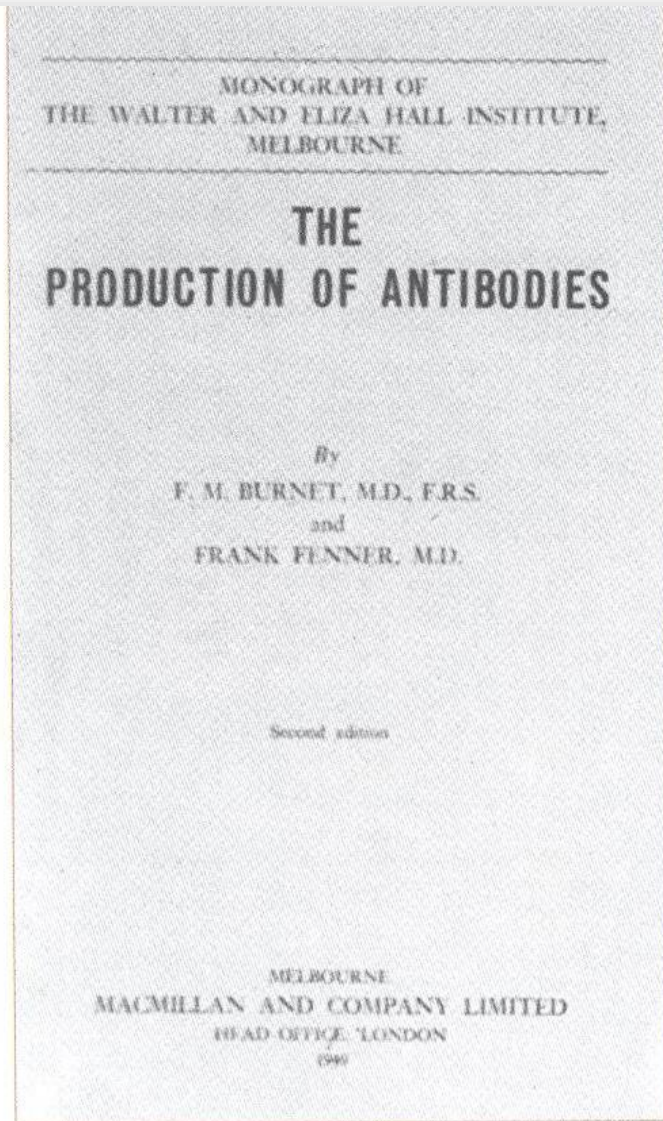

Figure 48 Burnet and Fenner's famous monograph

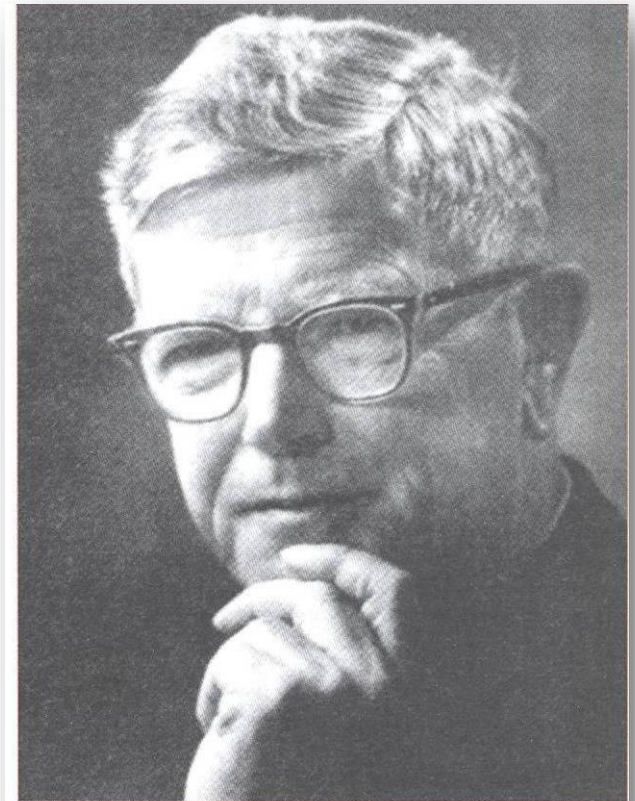

Figure 13 Sir F. Macfarlane Burnet, Nobel Laureate in Medicine, who described the clonal selection theory of acquired immunity

agar medium⁴. A formalinized broth culture containing about 10^9 organisms per ml. was used as the antigen. Adult Wistar rats were injected with 0.25 ml. of a mixture of equal parts of both antigens into both hind foot-pads. Usually the animals were given three pairs of injections at three weekly intervals. Three days after the tertiary injections, they were killed by exsanguination under anaesthesia. Both popliteal lymph nodes were removed, pooled, and processed⁵ to give dispersed cell suspensions in Earle's saline buffered to pH 7.0 with *tris*, and supplemented with 20 per cent normal rat serum. The cells were sedimented by gentle centrifugation, and washed three times to remove free soluble antibody. Single cells were then isolated in microdroplets by a simple modification^{4,5} of de Fonbrune's oil chamber method⁷. This consisted essentially of depositing tiny droplets (volume 10^{-7} - 10^{-6} ml.) on the surface of a coverslip and immersing them in paraffin oil. The coverslip was then inverted over a chamber filled with oil. The easiest method for preparing droplets containing one cell was to dispense a large number of droplets by free-hand manipulation from a suspension containing 1:400 by volume of lymph node cells. These droplets contained from nought to six cells; each droplet was later recorded for its cell content. Larger droplets containing up to 100 cells could also be prepared. Alternatively, droplets containing exactly one cell each could be prepared by micromanipulation, but this was more tedious, due to the adhesion of the cells to the micropipette. The oil chamber was then incubated at 37° C. for 4 hr. At the end of this time, the chamber was placed on a microscope and the droplets surveyed at one hundred-fold magnification, dark ground. With a micropipette controlled by de Fonbrune micromanipulator, about ten bacteria were introduced into each droplet. Half the droplets were inoculated with *S. adelaide*, and the other half with *S. typhi*. After twenty minutes at room temperature, the droplets were observed for motility of the organisms. Total loss of motility of all the organisms was recorded as 'inhibition'. If even one organism in the droplet remained motile, this was recorded as 'no inhibition'. For control purposes, the suspending medium, the final supernatant from the washings, and the whole cell suspension prior to incubation were all shown to be free of inhibitory activity. Droplets prepared from the final cell suspension but containing no cells were also scored and found to lack inhibitory activity. Cells from several untreated rats were tested and these failed to elaborate a factor inhibiting the motility of the bacteria. Antisera against each serotype showed negligible cross-reaction with the other.

A proportion of the cells from immunized animals developed a factor immobilizing the test bacteria, and this was presumed to be antibody. All droplets containing single cells which were seen to immobilize the first serotype were then inoculated with about ten organisms from the second. After a further twenty minutes at room temperature, they were again observed for motility. The results of a typical experiment are recorded in Table 1. They indicate that none of the single cells was able to immobilize the organisms of both strains. To date 456 single cells have been tested for antibody production, 228 against each of the two organisms. Out of these, 33 were active against *S. adelaide* and 29 against *S. typhi*, but none of the 62 immobilized both strains.

Table 1. ANTIBODY PRODUCTION BY ISOLATED CELLS

No. of cells in drop	No. of drops inhibitory	No. of drops tested
First tested versus <i>S. adelaide</i>		
1	6*	39
2	5	25
3	7	24
4	6	21
5	6	10
6-10	17	33
First tested versus <i>S. typhi</i>		
1	3*	18
2	6	26
3	0	14
4	3	14
5	1	8
6-10	22	42

Lymph node cells from rats pre-sensitized to *S. adelaide* plus *S. typhi* were dispensed in micro droplets and incubated for 4 hr. They were then tested by the introduction of motile bacteria.

* These droplets were also tested for activity against the alternative serotype and were negative.

These results imply that when an animal is stimulated with two contrasting antigens, individual cells tend to form one species of antibody. We cannot exclude a residual production of other antibodies at lower rates. The experiments were provoked by current hypotheses on the role of clonal individuation in antibody formation^{8,9}, with which they are consistent so far as they go. However, further studies will be needed to determine whether the assortment of antibody-forming phenotypes reflects a genotypic restriction or whether it is more akin to such phenotypic effects as interference between related viruses, or diauxie and competition in enzyme formation.

We are indebted to Sir Macfarlane Burnet for his interest, encouragement and hospitality. This work was aided by a grant from the National Health and Medical Research Council, Canberra, Australia. It was done as part fulfilment of the requirements for the degree of doctor of philosophy in the University of Melbourne (G. J. V. N.).

G. J. V. NOSSAL
JOSHUA LEDERBERG*

Walter and Eliza Hall Institute
of Medical Research,
Melbourne.
March 25.

* Fulbright Visiting Professor of Bacteriology, University of Melbourne; from Department of Medical Genetics, University of Wisconsin, Madison.

¹ Fagreus, A., *J. Immunol.*, 58, 1 (1945).

² Thorbecke, G. J., and Keuning, F. J., *J. Immunol.*, 70, 129 (1953).

³ Wesslen, T., *Acta Dermatol-Venerol.*, 32, 265 (1952).

⁴ Lederberg, J., *Genetics*, 41, 845 (1956).

⁵ Lederberg, J., *J. Bacteriol.*, 68, 258 (1954).

⁶ Harris, S., Harris, T. N., and Farber, M. B., *J. Immunol.*, 72, 148 (1954).

⁷ De Fonbrune, P., "Technique de micromanipulation" (Masson, Paris 1949).

⁸ Burnet, F. M., *Austral. J. Sci.*, 20, 67 (1957).

⁹ Talmage, D. W., "Ann. Rev. Med.", 8, 239 (1957).

Antibody Production by Single Cells

FAGREUS¹ and others^{2,3} have shown that certain tissues from pre-sensitized animals can form antibody *in vitro*. This communication describes a technique whereby antibody production by single cells isolated in microdroplets can be detected. The technique is based on specific immobilization of *Salmonella* serotypes by anti-flagellar antibody. It was observed that single cells from a rat, simultaneously stimulated with two antigens, formed detectable amounts of one or the other antibody.

Two monophasic *Salmonellae* were used: *S. adelaide*, flagellar antigen H_{19} , and *S. typhi*, H_{1d} . They were maintained at maximum motility by frequent passages through a semi-solid nutrient gelatin

THE CLONAL
SELECTION THEORY OF
ACQUIRED IMMUNITY

BY
SIR MACFARLANE BURNET
O.M., F.R.S.

THE
ABRAHAM FLEXNER LECTURES OF
VANDERBILT UNIVERSITY
1958

CAMBRIDGE
AT THE UNIVERSITY PRESS
1959

PUBLISHED IN U.S.A. BY
VANDERBILT UNIVERSITY PRESS
NASHVILLE, TENNESSEE

Figure 14 Dr Burnet's famous book describing clonal selection, for which he was awarded the Nobel Prize in Medicine

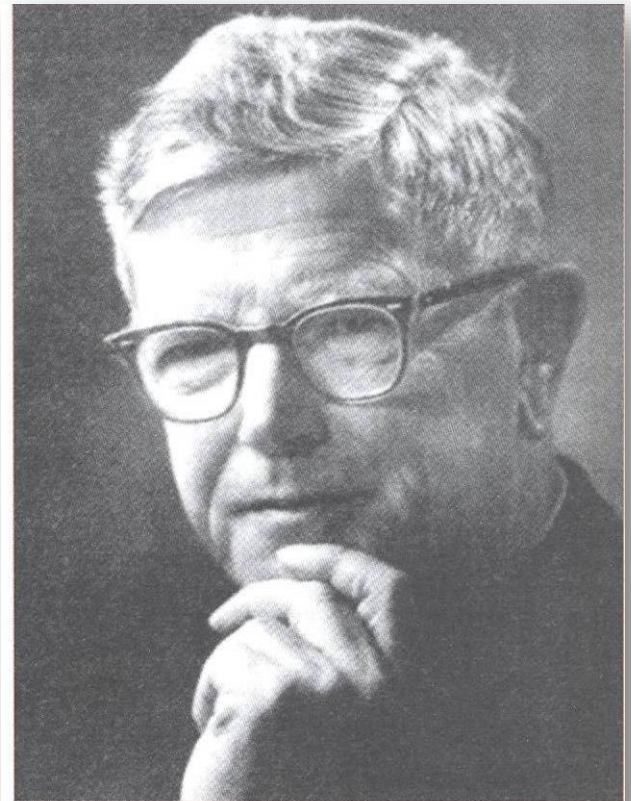

Figure 13 Sir F. Macfarlane Burnet, Nobel Laureate in Medicine, who described the clonal selection theory of acquired immunity

Clonal selection theory, Burnet F.M., 1959

1. Κάθε λεμφοκύτταρο φέρει στην επιφάνειά του πολυάριθμα αντίγραφα ενός μοναδικού υποδοχέα ειδικό για κάποιο ξένο αντιγόνο
2. Αναγνώριση μέσω του επιφανειακού υποδοχέα και ενδοκυττάρια μεταφορά του σήματος αποτελεί το εναρκτήριο γεγονός της ανοσολογικής απάντησης
3. Τα λεμφοκύτταρα των οποίων ο επιφανειακός υποδοχέας αναγνωρίζει ίδια (self) αντιγόνα εξαλείφονται πρώιμα στη ζωή

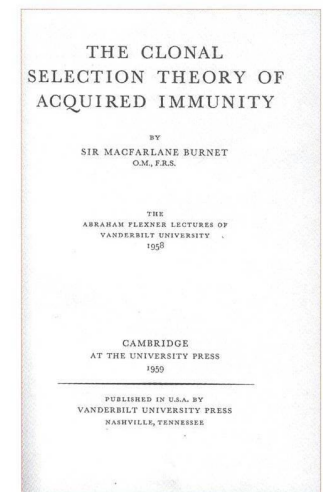

Figure 14 Dr Burnet's famous book describing clonal selection, for which he was awarded the Nobel Prize in Medicine

Clonal selection theory, Burnet F.M., 1959

1. Κάθε λεμφοκύτταρο φέρει έναν μοναδικό υποδοχέα

2. Αναγνώριση μέσω του υποδοχέα μεταφορά του σήματος απάντησης

3. Τα λεμφοκύτταρα των ίδιων (self) αντιγόνων εξαλείφονται

πολύ αριθμός αντιγράφων του αντιγόνου

αυτά ενδοκυττάρια αντιγόνων της ανοσολογικής

υποδοχέας αναγνωρίζει

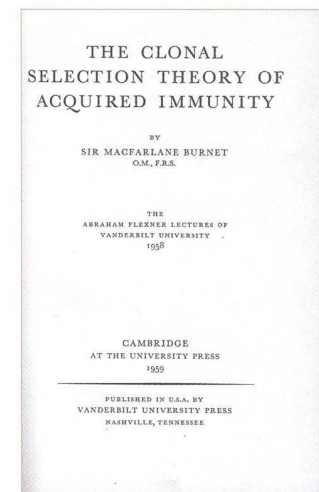
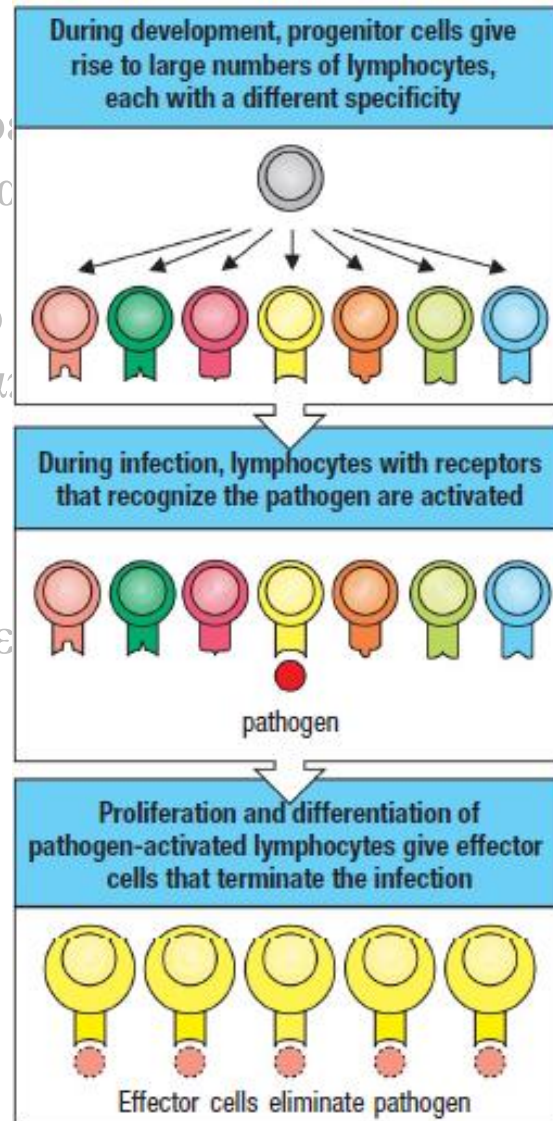

Figure 14 Dr Burnet's famous book describing clonal selection, for which he was awarded the Nobel Prize in Medicine

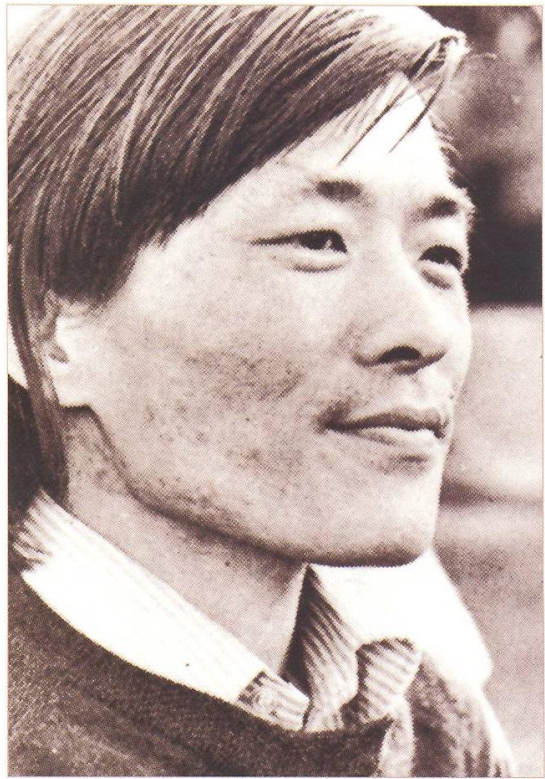

Figure 58 Susumu Tonegawa

From: *Historical Atlas of Immunology*

Proc. Natl. Acad. Sci. USA
 Vol. 73, No. 10, pp. 3628-3632, October 1976
 Genetics

Evidence for somatic rearrangement of immunoglobulin genes coding for variable and constant regions

(κ -chain mRNA/restriction enzymes/RNA-DNA hybridization)

NOBUMICHI HOZUMI AND SUSUMU TONEGAWA

Basel Institute for Immunology, 487, Grenzacherstrasse, CH-4058 Basel, Switzerland

Communicated by N. K. Jerne, July 2, 1976

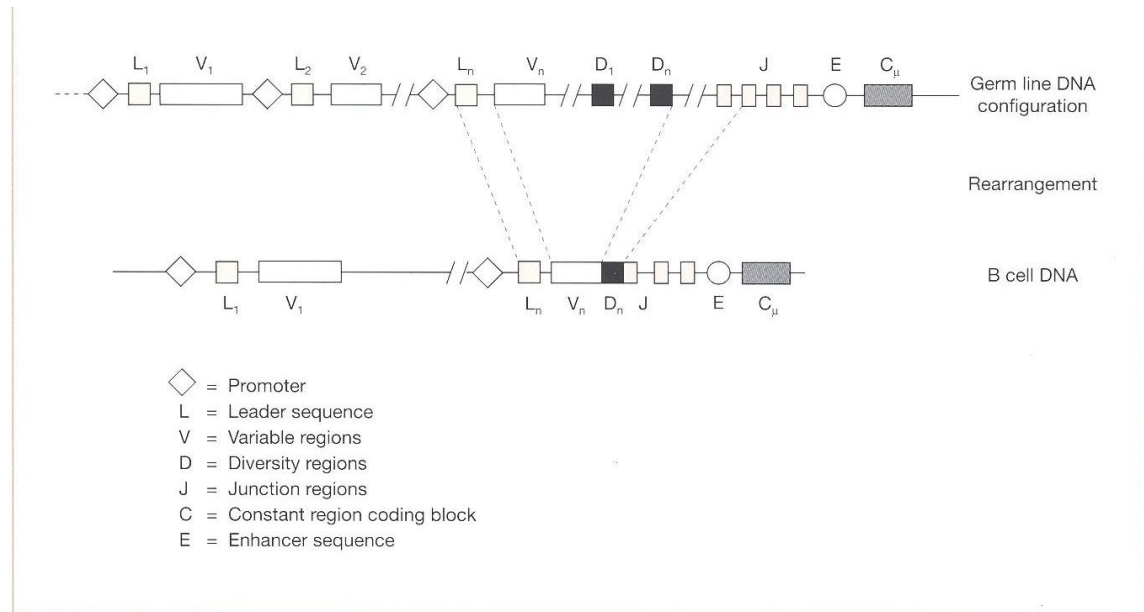
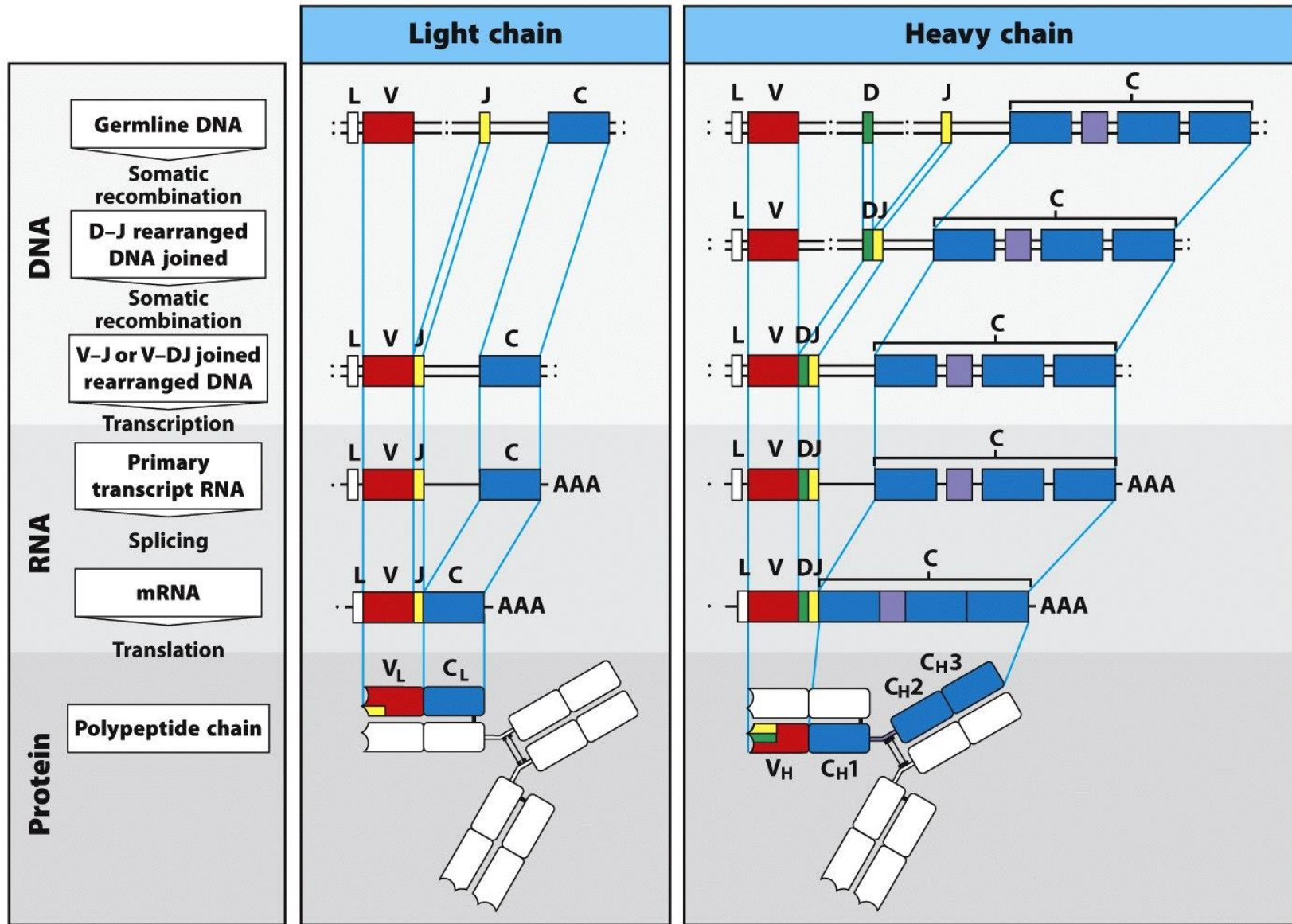

Figure 59 Immunoglobulin gene rearrangement

Το ρεπερτόριο των αντισωμάτων



11/04/2020
Figure 4-2 Immunobiology, 7ed. (© Garland Science 2008)

Το ρεπερτόριο των αντισωμάτων και των T κυτταρικών υποδοχέων

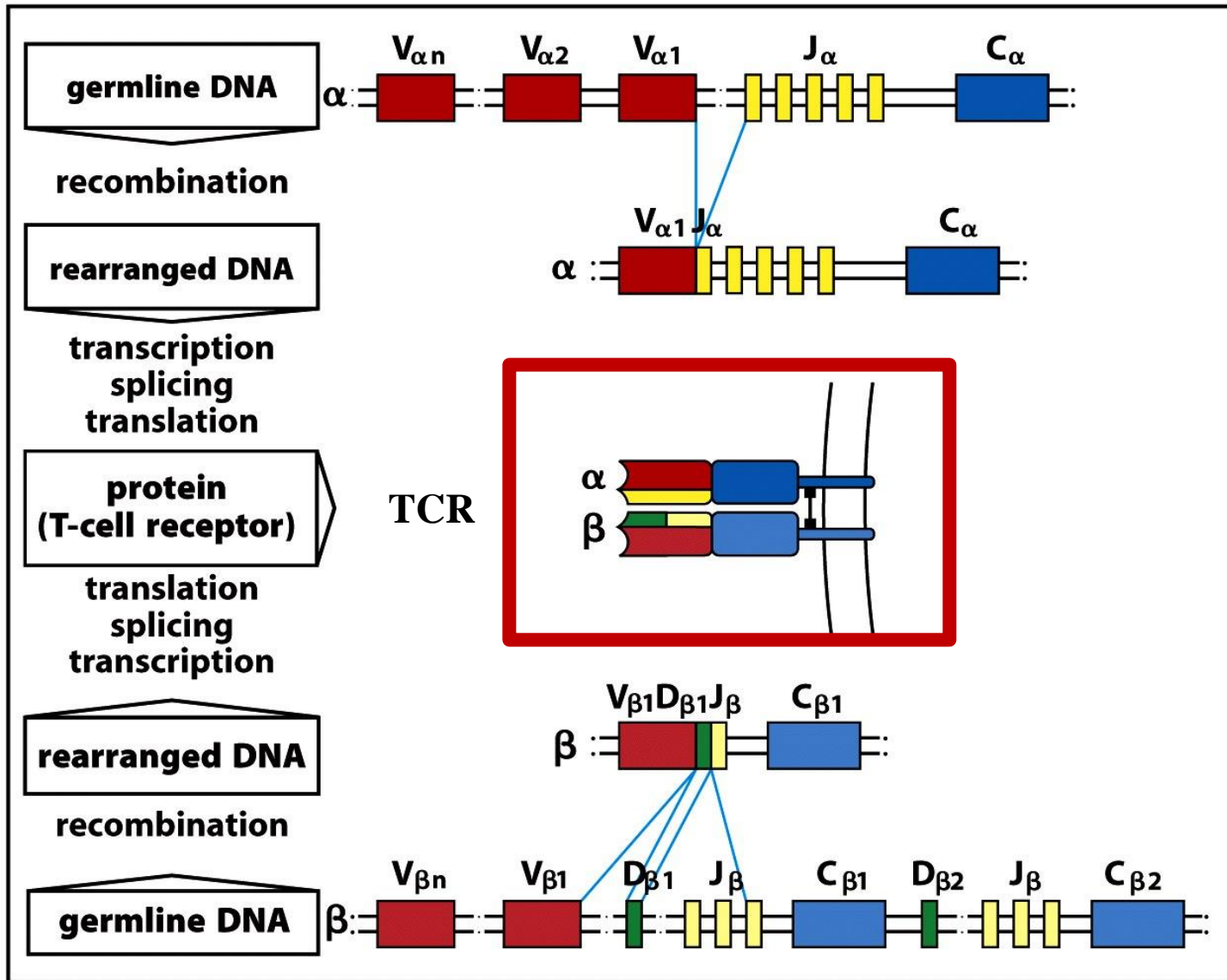
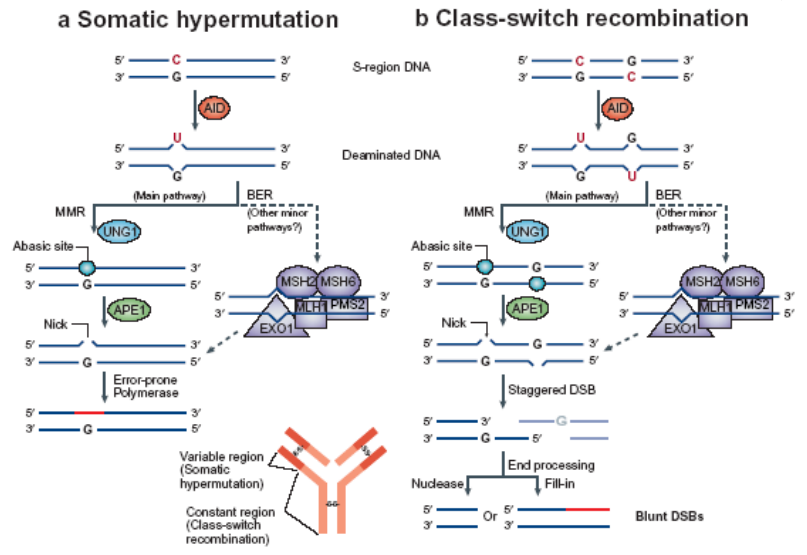
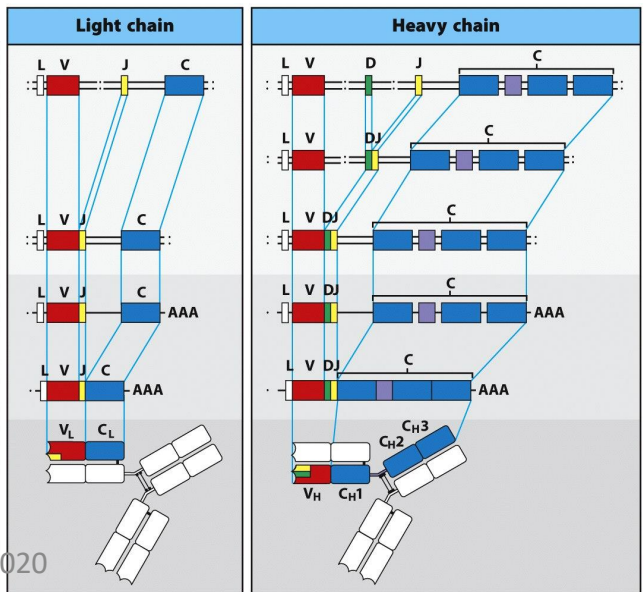
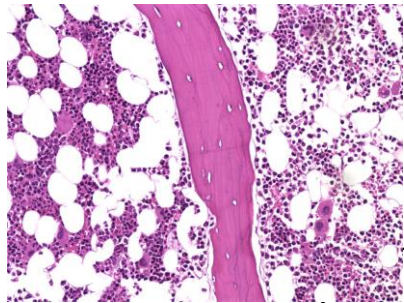
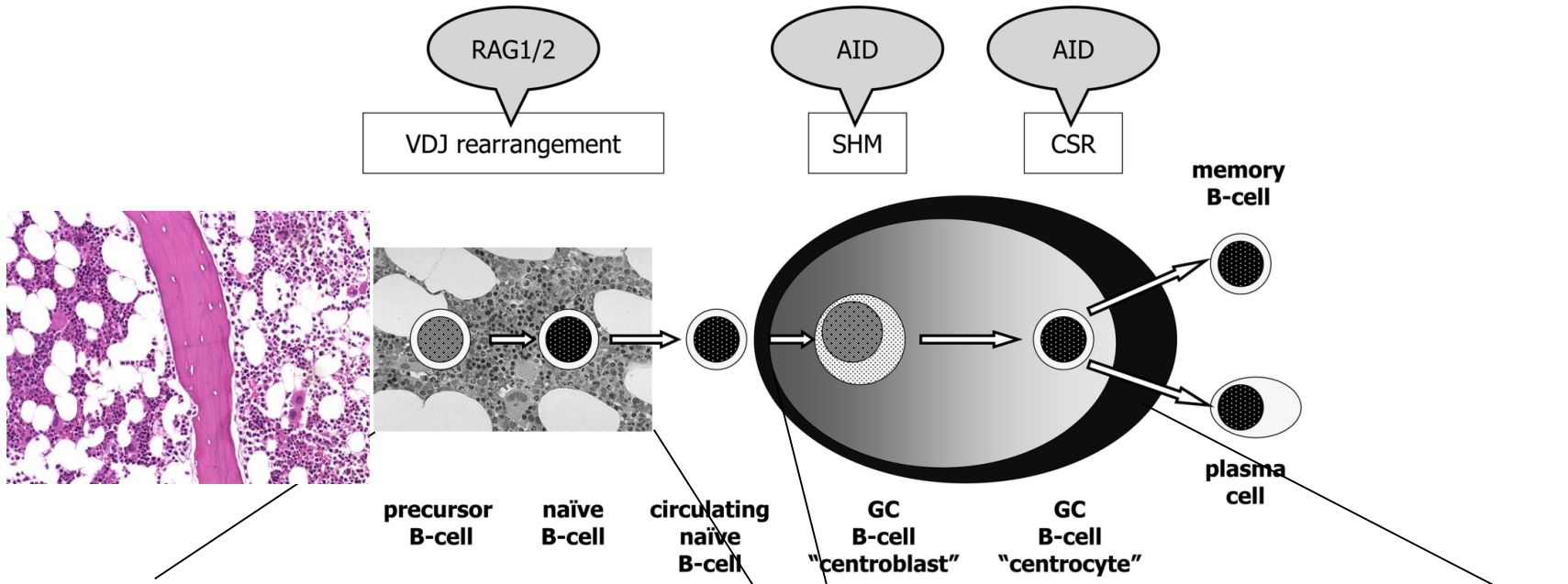

Figure 4-10 Immunobiology, 7ed. (© Garland Science 2008)

Το ρεπερτόριο των αντισωμάτων και των T κυτταρικών υποδοχέων

Element	Immunoglobulin		α:β T-cell receptors	
	H	κ+λ	β	α
Variable segments (V)	40	70	52	~70
Diversity segments (D)	25	0	2	0
D segments read in three frames	rarely	–	often	–
Joining segments (J)	6	5(κ) 4(λ)	13	61
Joints with N- and P-nucleotides	2	50% of joints	2	1
Number of V gene pairs	1.9 x 10 ⁶		5.8 x 10 ⁶	
Junctional diversity	~3 x 10 ⁷		~2 x 10 ¹¹	
Total diversity	~5 x 10 ¹³		~10 ¹⁸	



11/02/2020

Figure 4-2 Immunobiology, 7ed. © Garland Science 2008

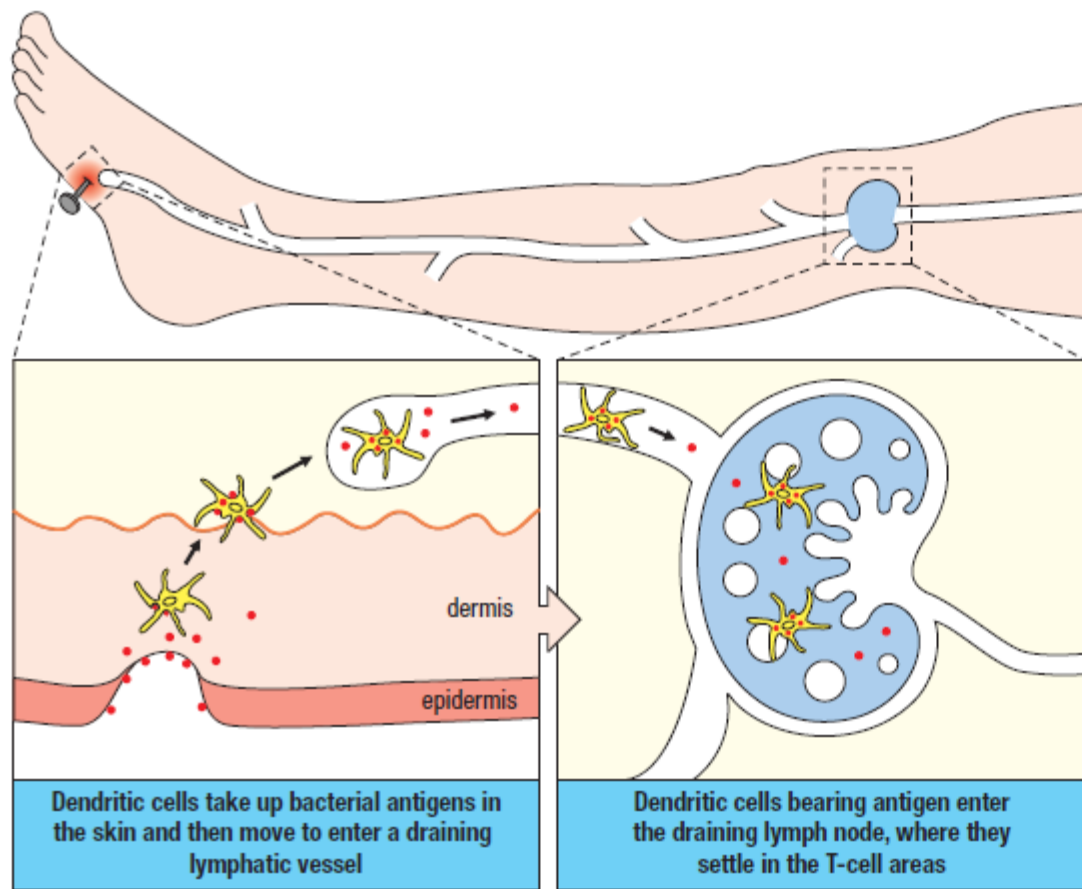
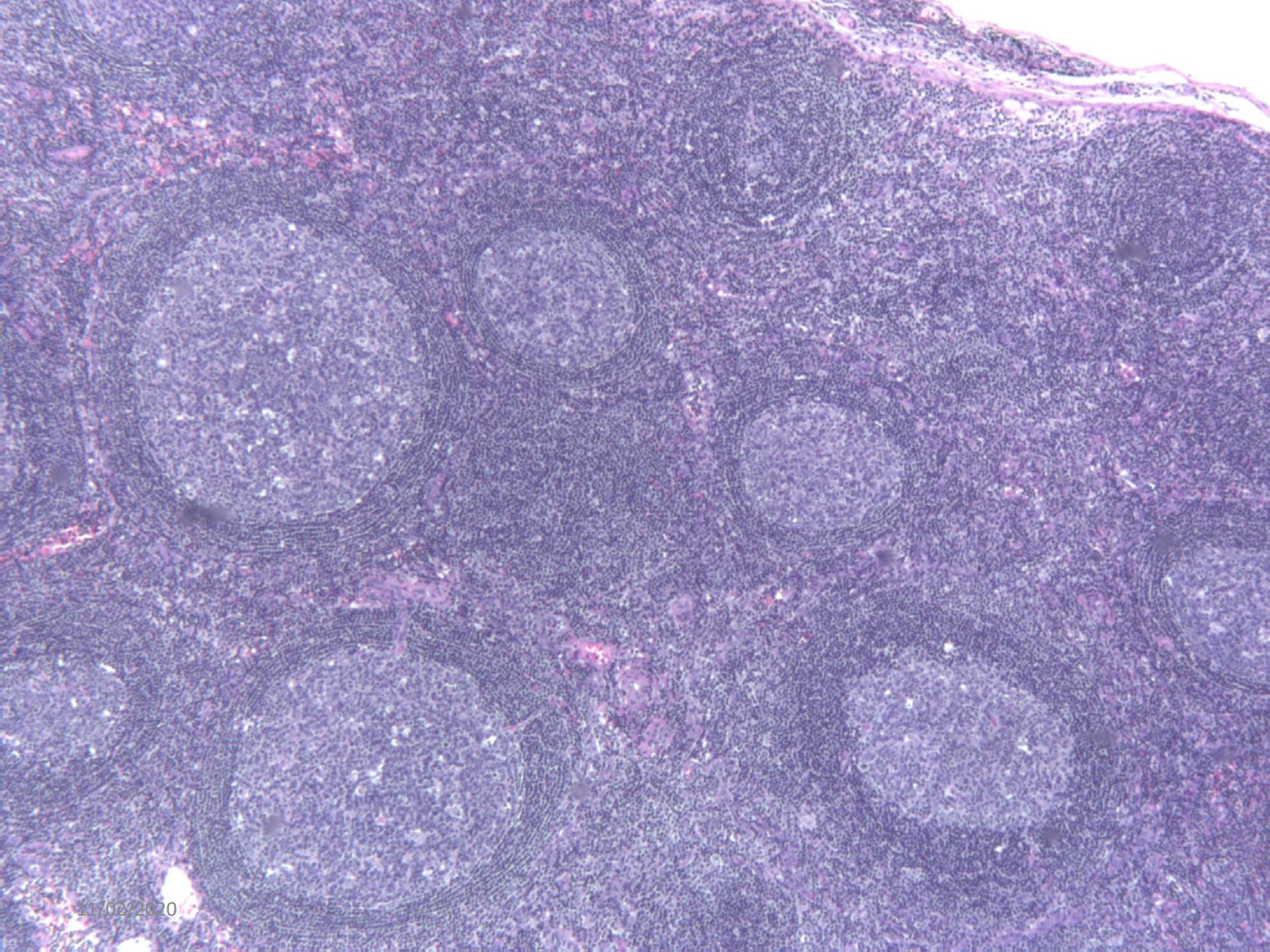
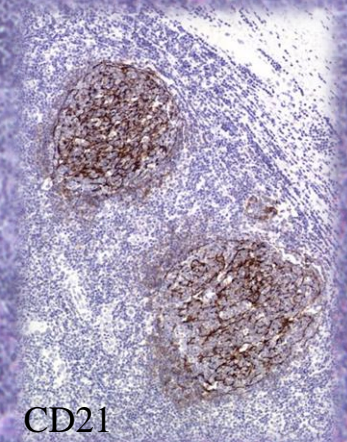
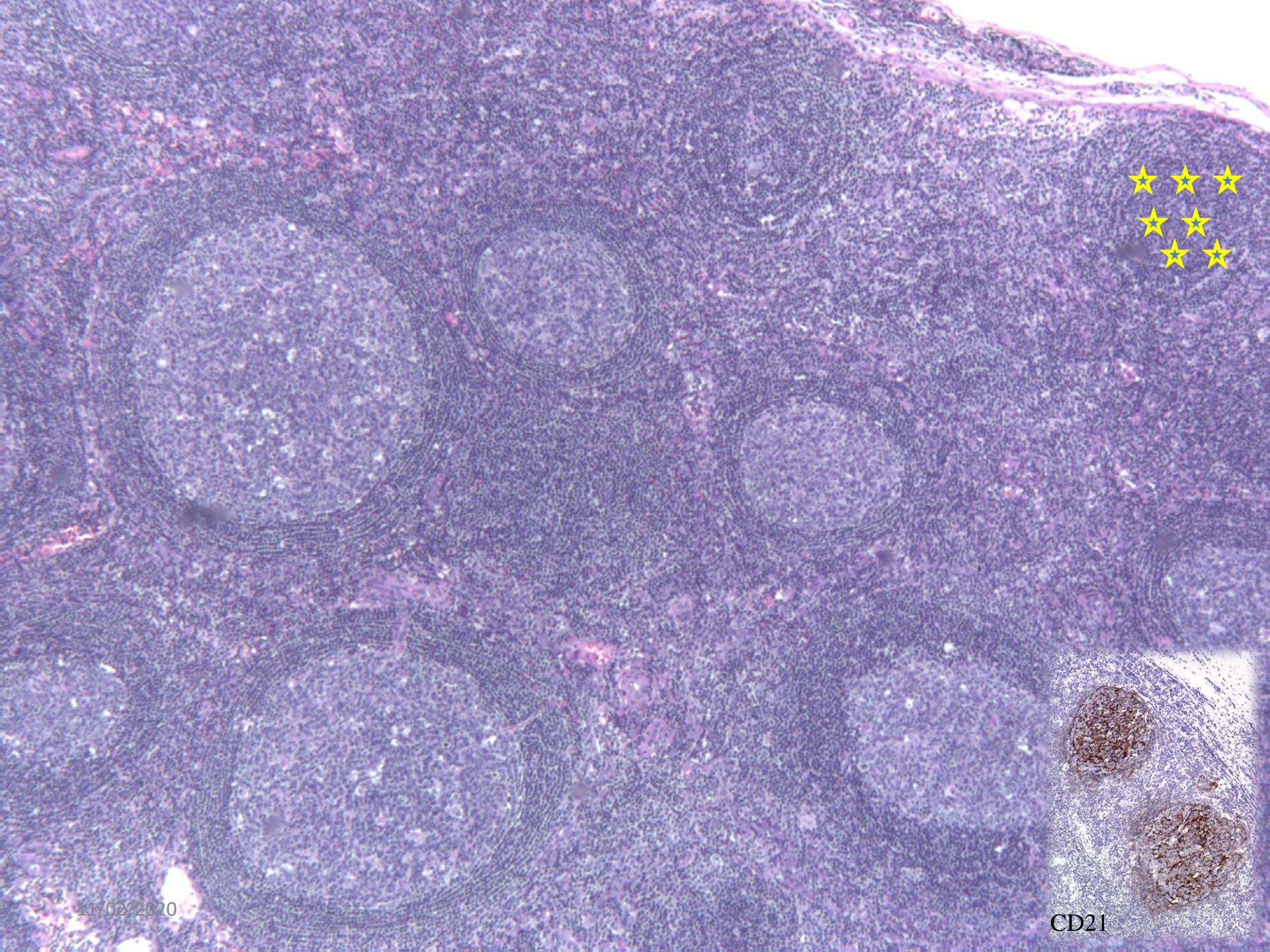

Figure 8.1 Dendritic cells take up antigens at a site of wounding and infection in the skin and carry them to the draining lymph node for presentation to naive T cells. Dendritic cells in the skin are immature and specialized in the uptake of pathogens and their antigens (red dots). On migration to the lymph node, they settle in the T-cell areas and differentiate into mature dendritic cells that are specialized in activating naive T cells. The immature dendritic cells in the skin, also known as Langerhans cells, are distinguished morphologically by their Birbeck granules (not shown), which are part of the system of endosomal vesicles.



11/02/2020



11/02/2020

CD21

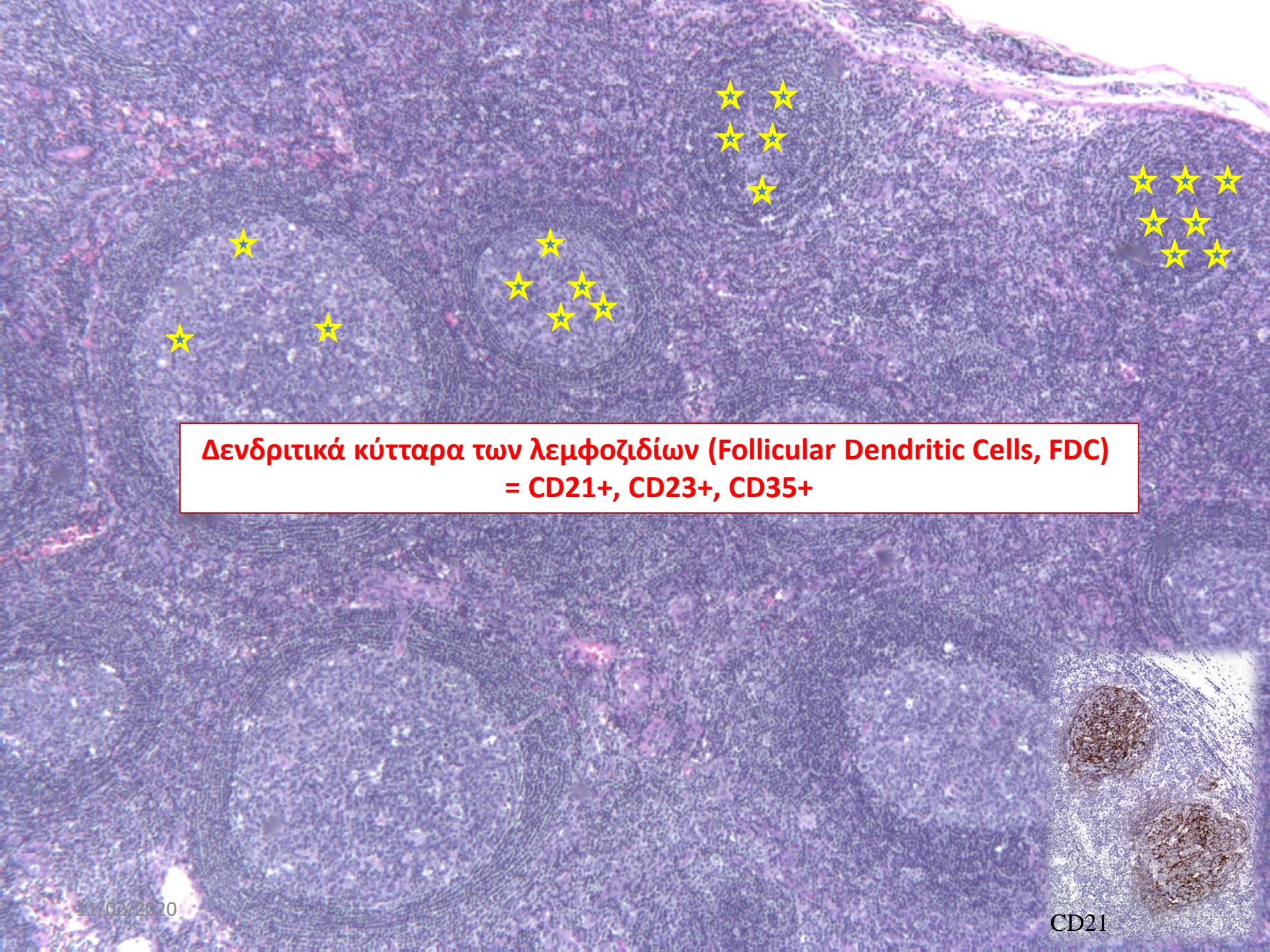

**Δενδριτικά κύτταρα των λεμφοζιδίων (Follicular Dendritic Cells, FDC)
= CD21+, CD23+, CD35+**

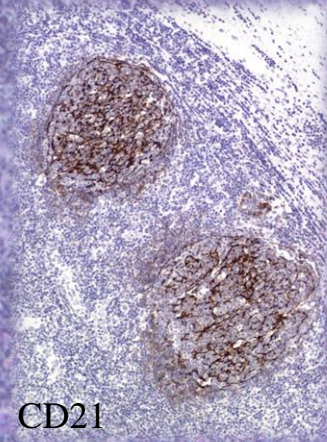

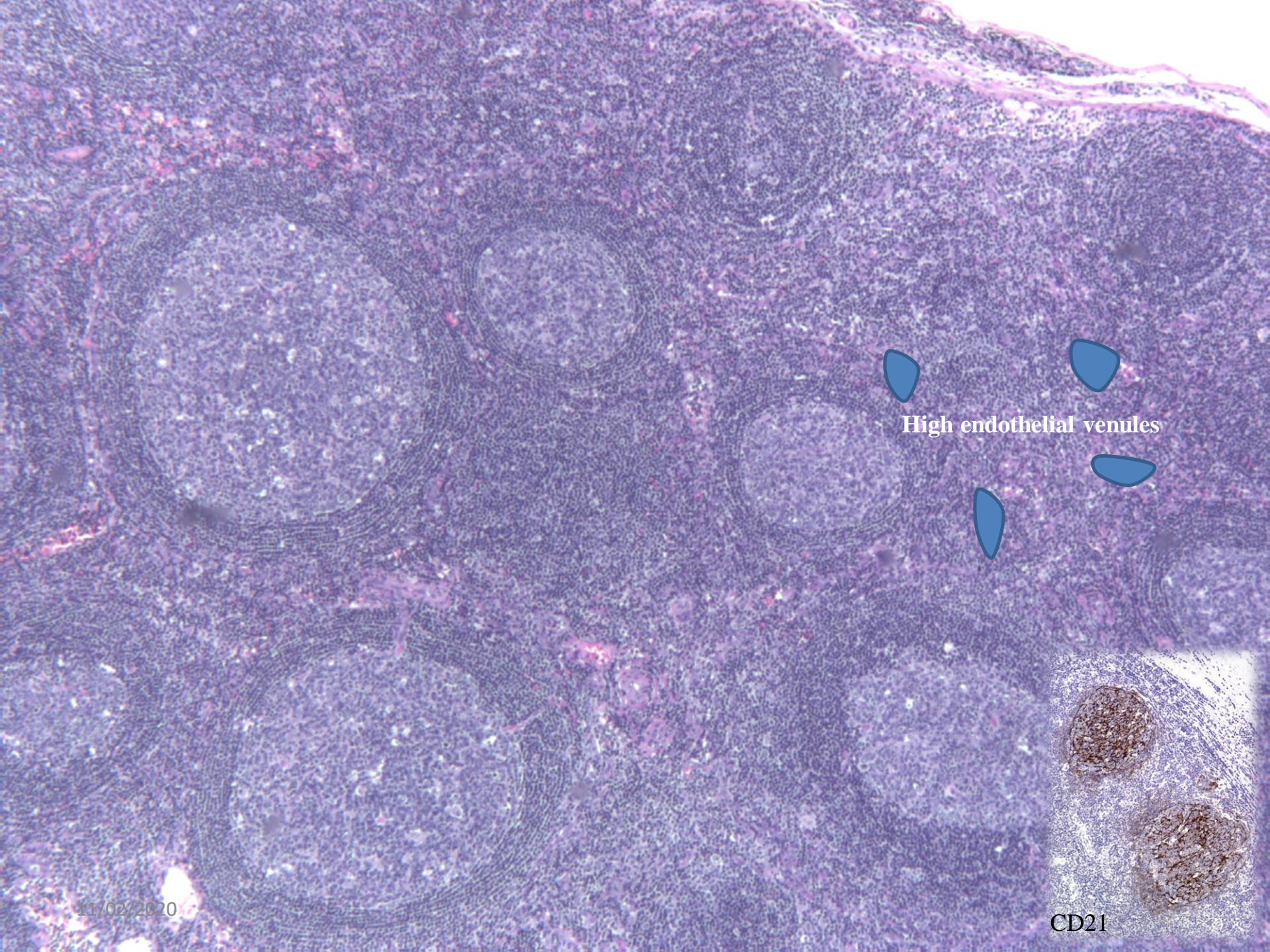

High endothelial venules

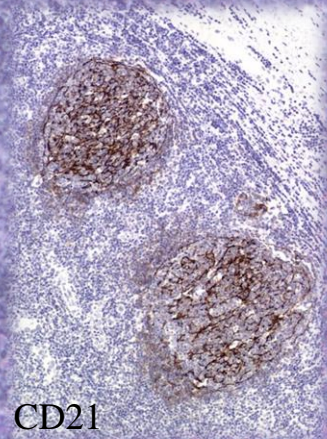

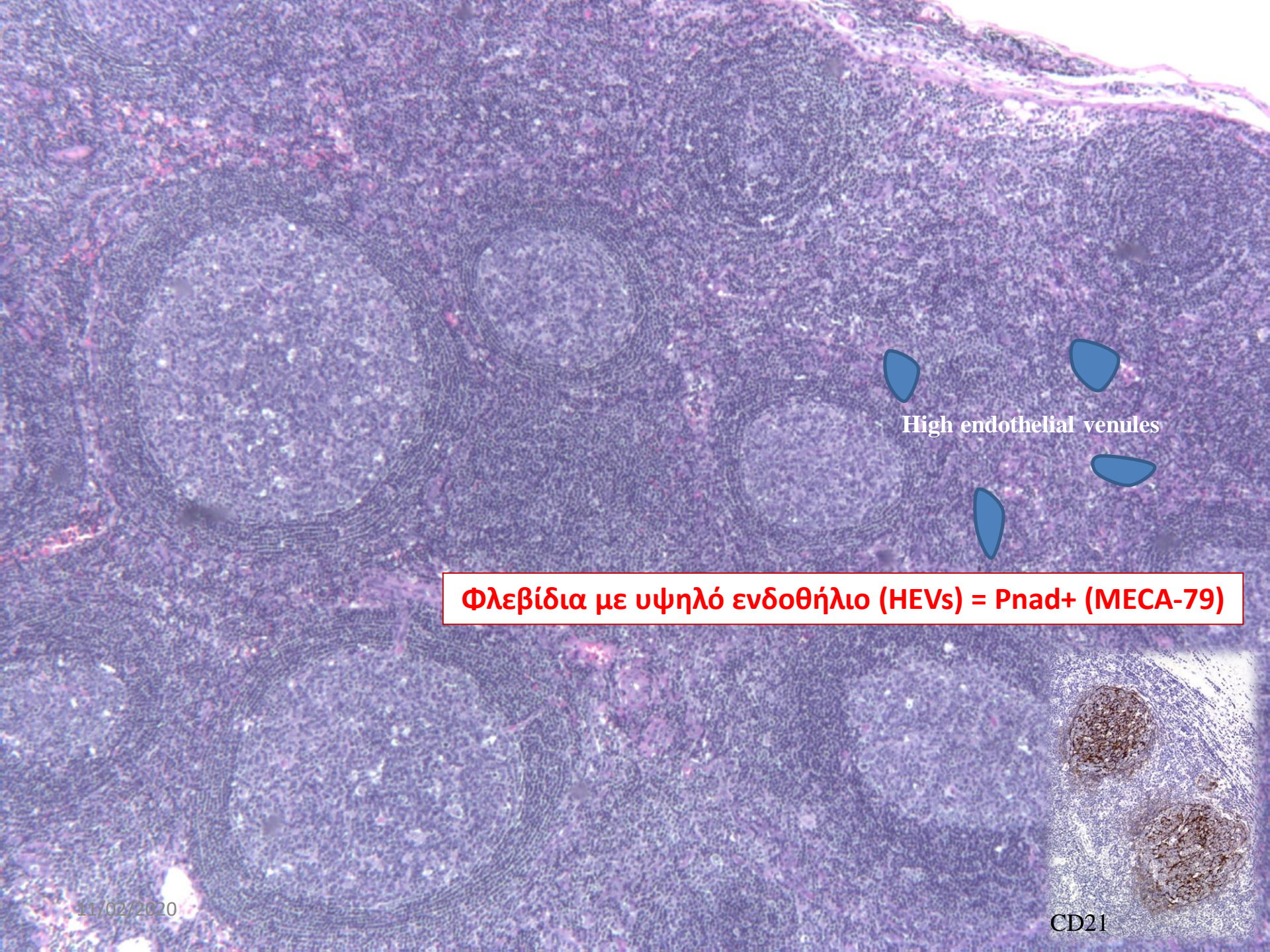

High endothelial venules

Φλεβίδια με υψηλό ενδοθήλιο (HEVs) = Pna⁺ (MECA-79)

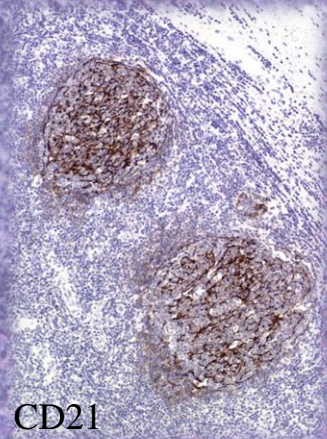

10.000 lymphocytes/sec/lymph node

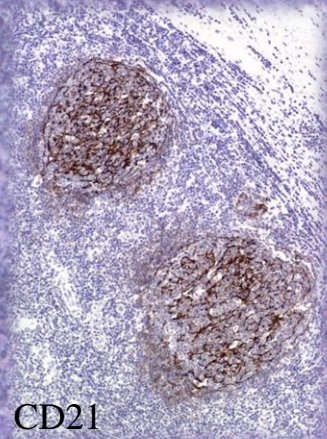
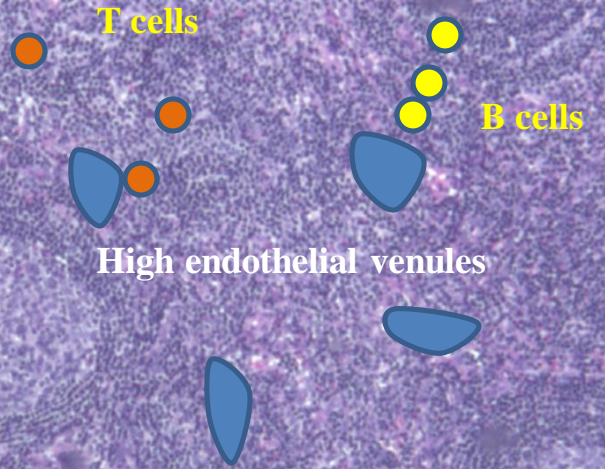
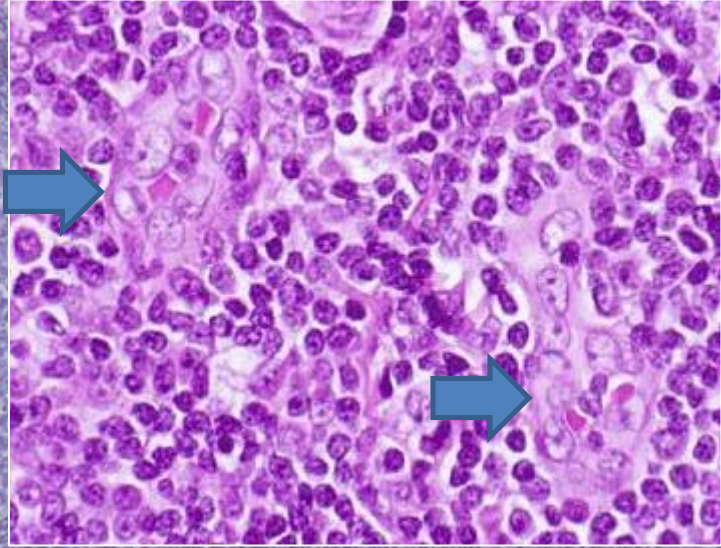

10.000 lymphocytes/sec/lymph node

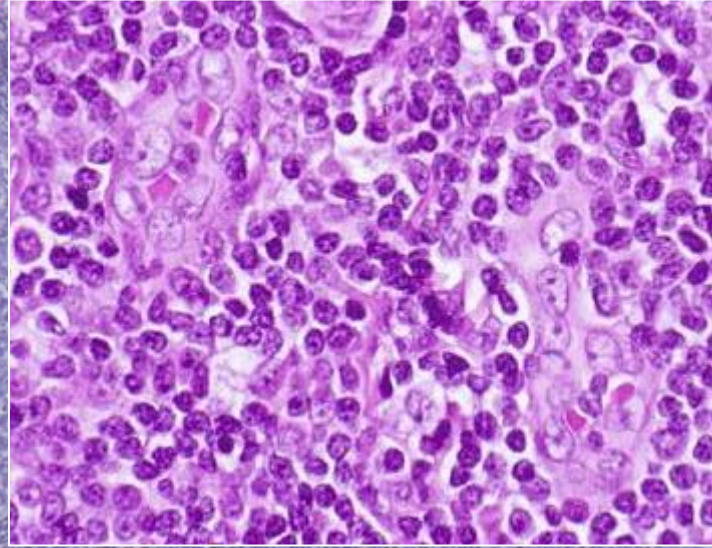

DCs
CCL19
CCL21

An icon of a dendritic cell (DC) with a red and black U-shaped receptor on its surface, emitting blue lines representing chemokines (CCL19 and CCL21).

FDCs
CXCL13

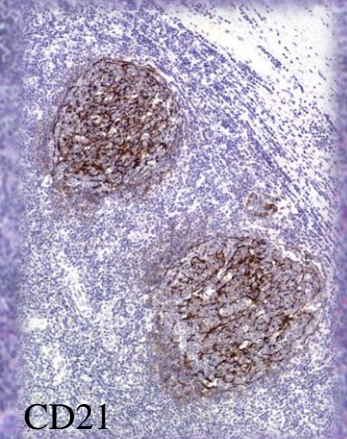
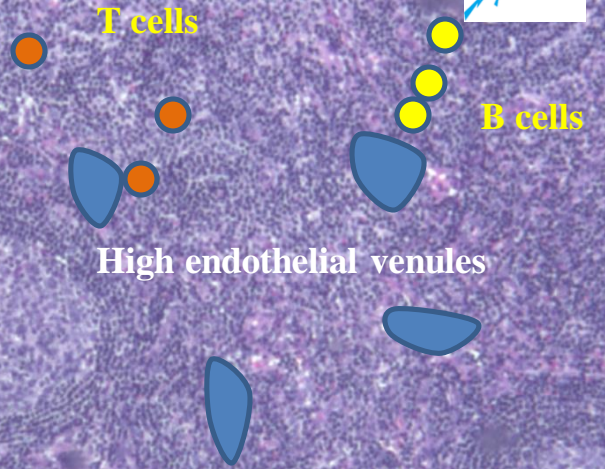
An icon of a follicular dendritic cell (FDC) with a red and black U-shaped receptor on its surface, emitting blue lines representing chemokine CXCL13.

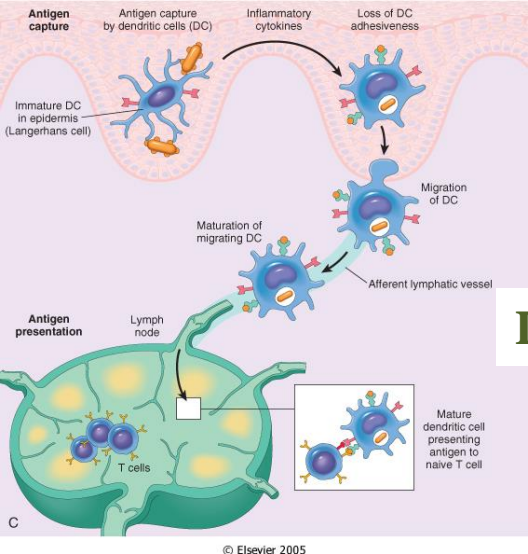

Μεταφορά αντιγόνων στους λεμφαδένες

Dendritic cells

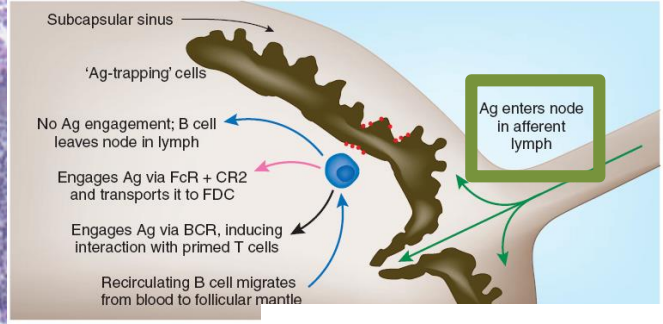

Διαλυτά αντιγόνα

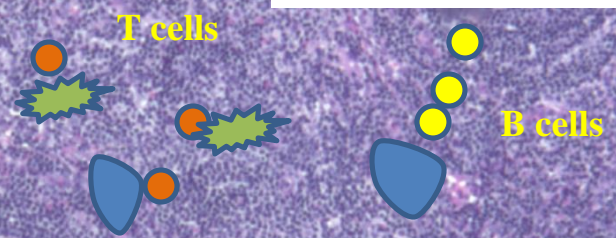

High endothelial venules

Μεταφορά αντιγόνων στους λεμφαδένες

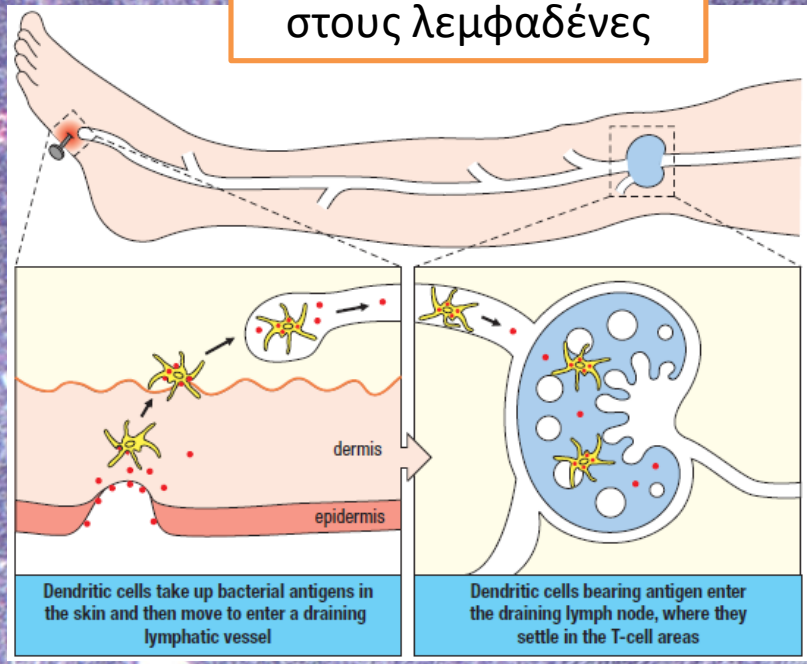
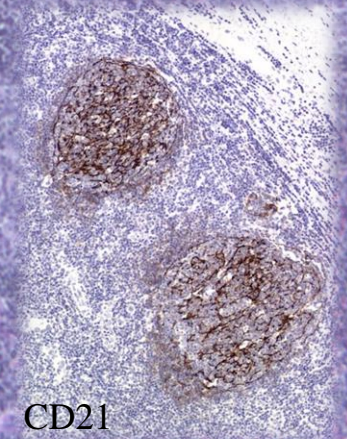
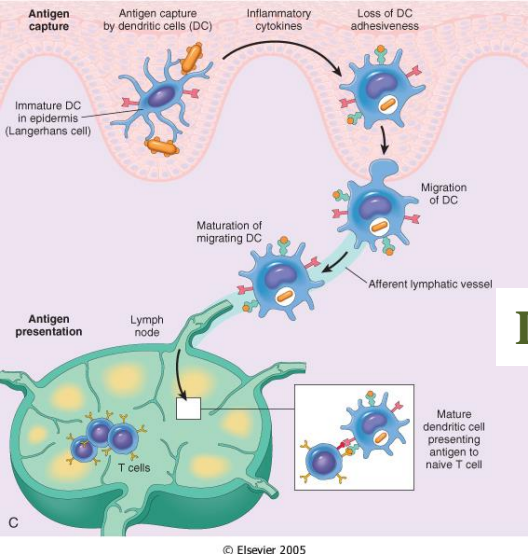
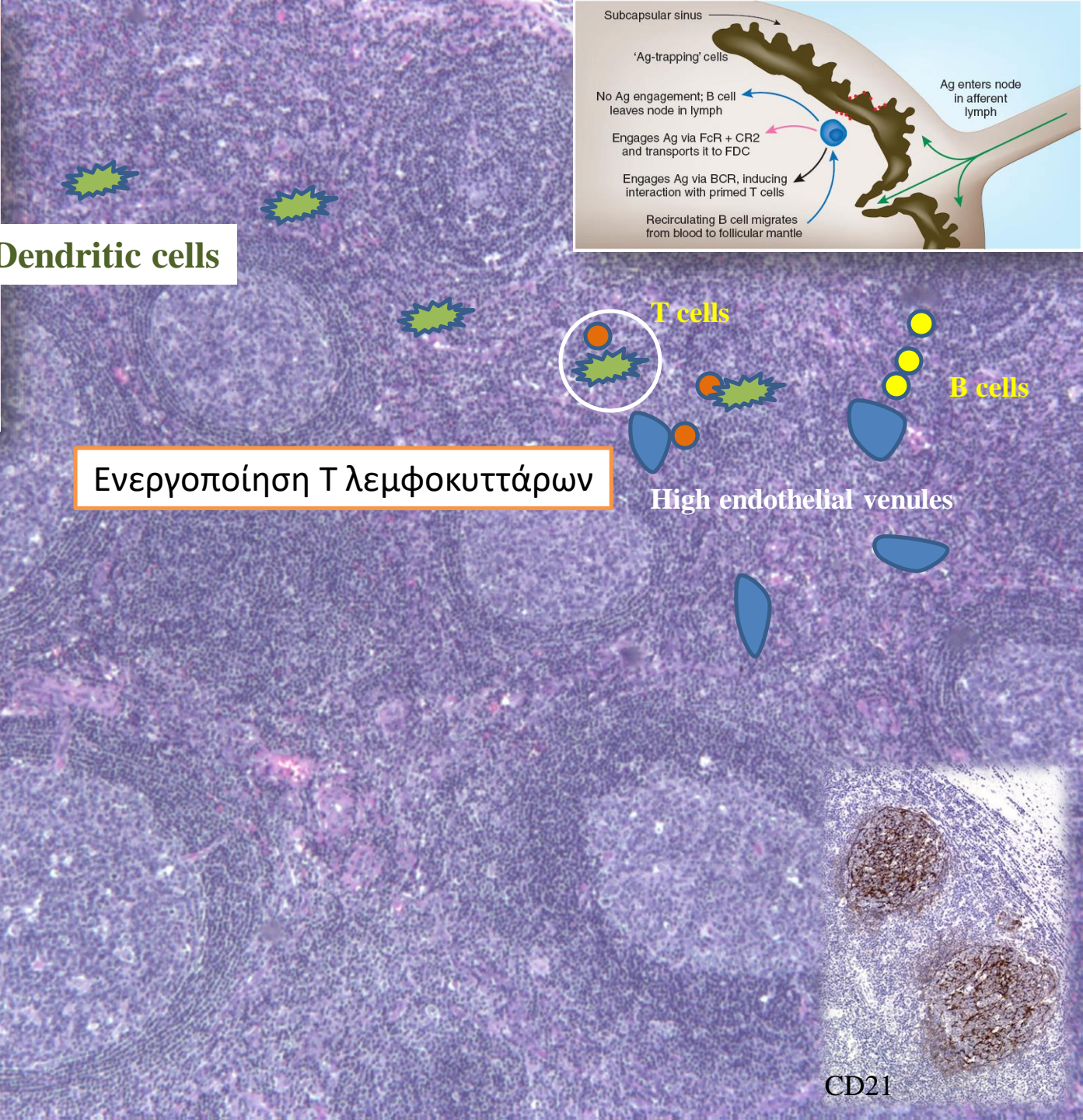
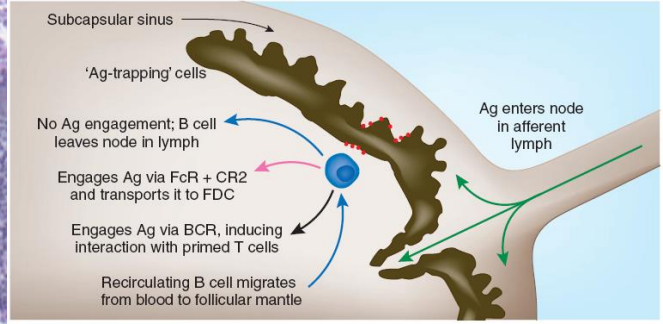

Figure 8.1 Dendritic cells take up antigens at a site of wounding and infection in the skin and carry them to the draining lymph node for presentation to naive T cells. Dendritic cells in the skin are immature and specialized in the uptake of pathogens and their antigens (red dots). On migration to the lymph node, they settle in the T-cell areas and differentiate into mature dendritic cells that are specialized in activating naive T cells. The immature dendritic cells in the skin, also known as Langerhans cells, are distinguished morphologically by their Birbeck granules (not shown), which are part of the system of endosomal vesicles.





Dendritic cells



Ενεργοποίηση Τ λεμφοκυττάρων

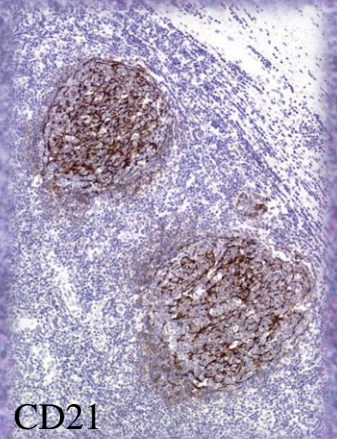

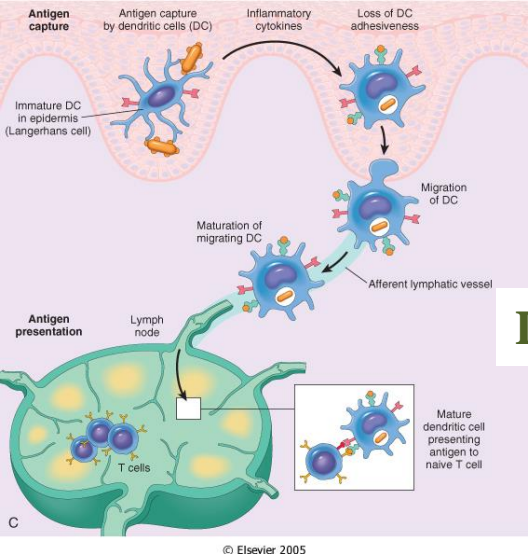

Dendritic cells

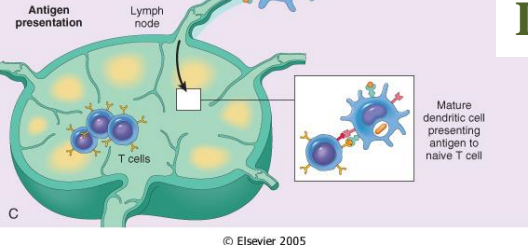
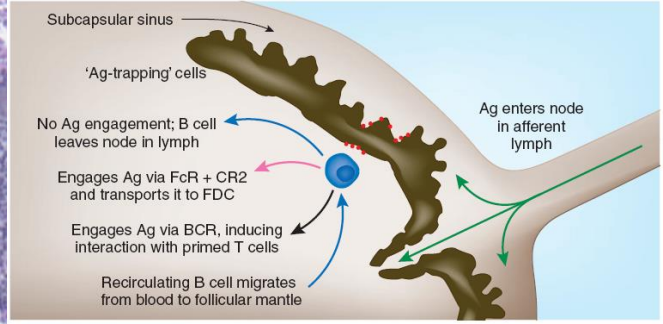

© Elsevier 2005

Ενεργοποίηση Τ λεμφοκυττάρων

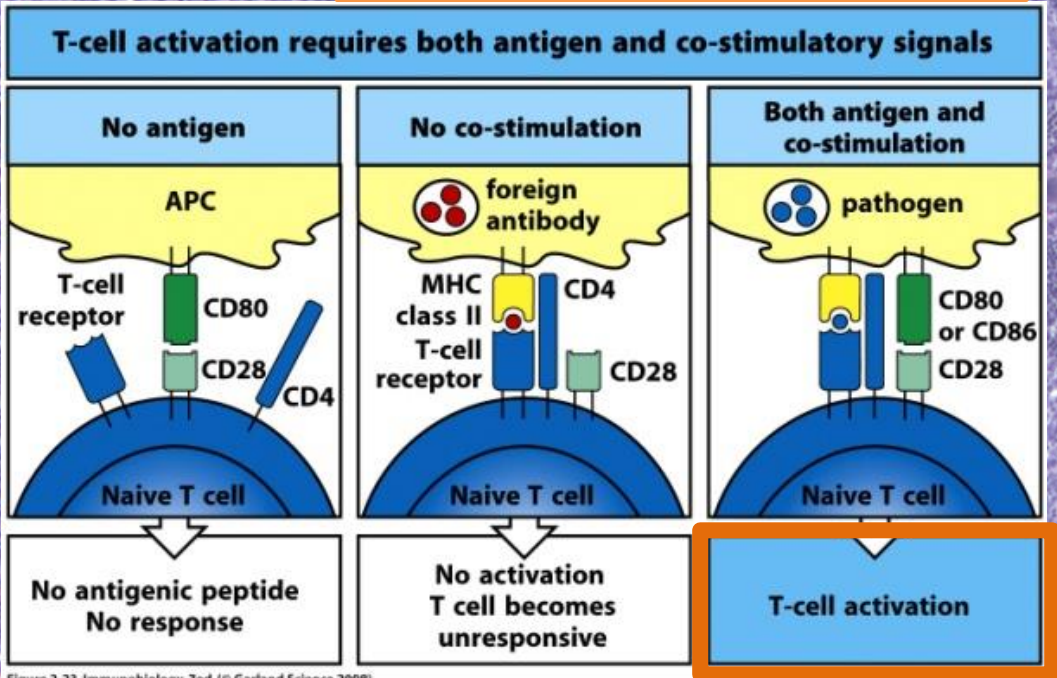
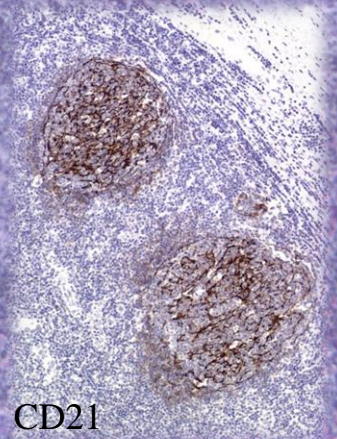
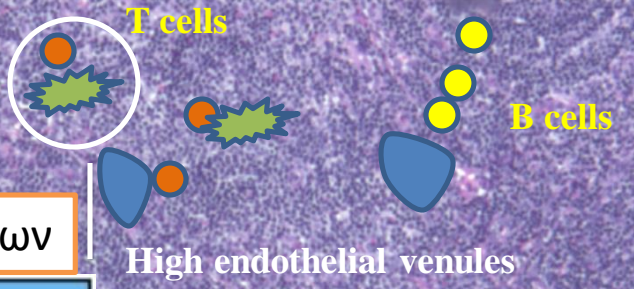
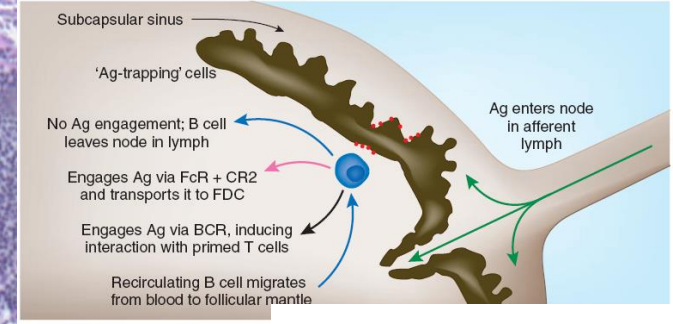

Figure 2-23 Immunobiology, 7ed. (© Garland Science 2008)



CD21

Ενεργοποίηση Β λεμφοκυττάρων



Διαλυτά αντιγόνα

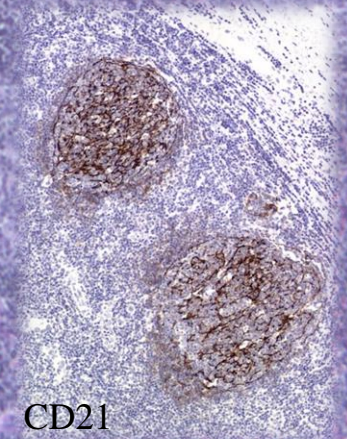
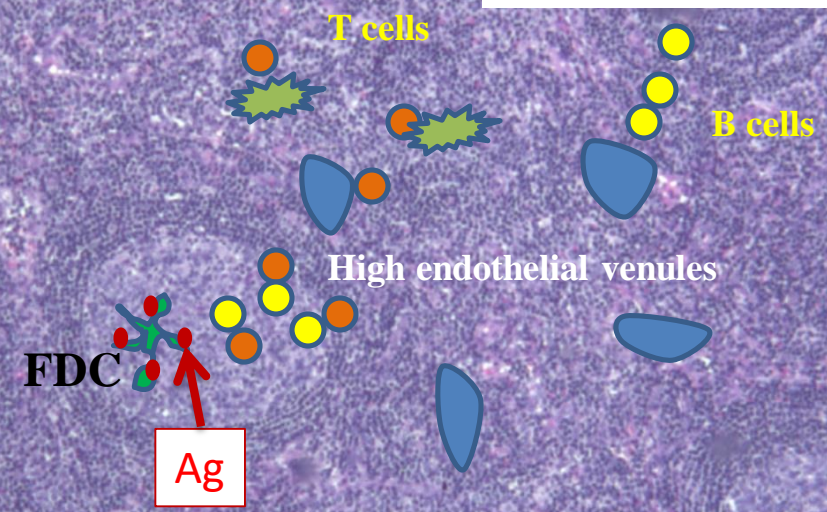

Ενεργοποίηση Β λεμφοκυττάρων

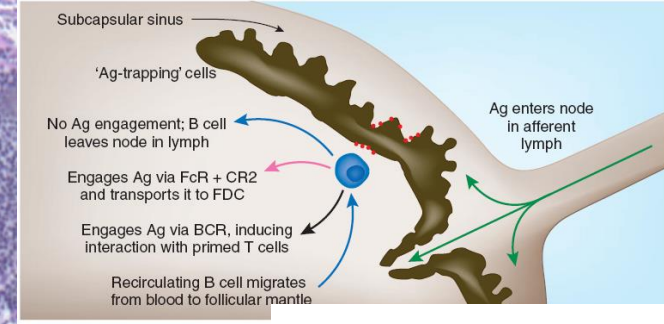
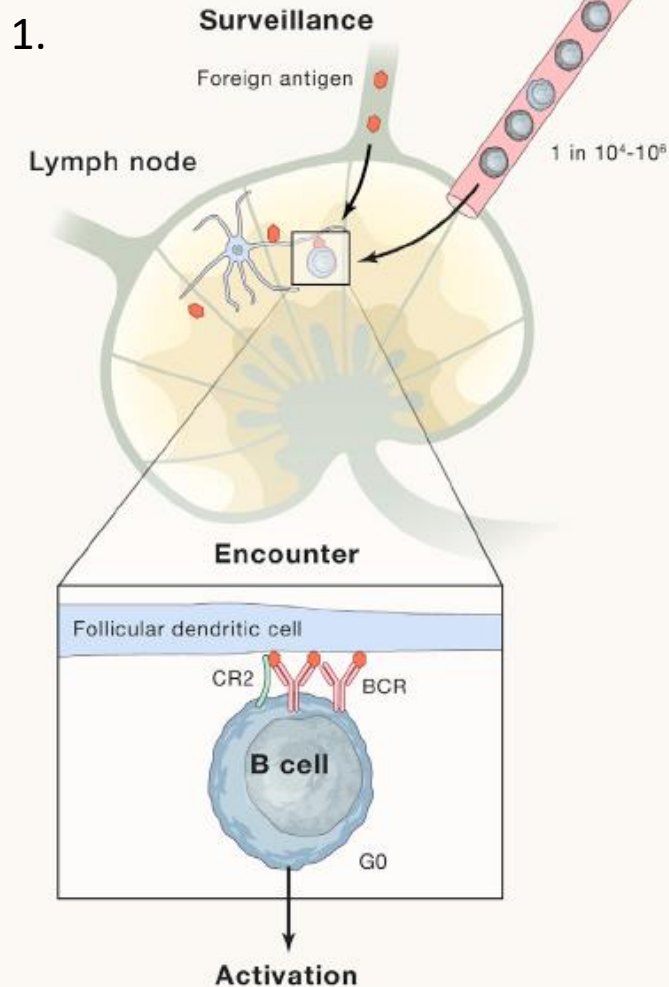

Διαλυτά αντιγόνα

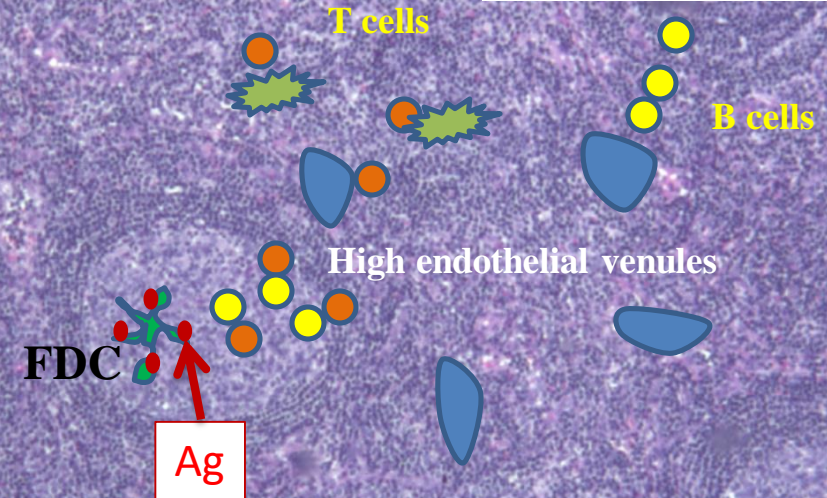

Circulating antigen-specific B cells (blue) that are as rare as 1 in 10^4 to 1 in 10^6 enter and survey an antigen-draining lymph node (LN). A B cell encounters an opsonized (complement coated) antigen displayed on a follicular dendritic cell (FDC) process and receives B cell receptor (BCR) and complement receptor-2 (CR2) signals. Activation involves upregulation of surface molecules, antigen internalization processing and (in the case of protein-containing antigens) presentation as MHC class II peptide (MHCII_{pep}) complexes, and entry into G1 of cell cycle. If the antigen engages multiple BCRs and/or coreceptors on the B cell, a T-independent (TI) proliferative response ensues. Lower valency protein-containing antigens drive T-dependent (TD) responses, where the B cell depends on signals from helper T cells to undergo proliferation. The proliferative phase is followed by differentiation into short-lived plasma cells (SLPCs), germinal center (GC) B cells, and/or memory B cells (Bmem). The relative differentiation to these distinct states varies and depends on the integration of signals received by the B cell including via the BCR, co-receptors, and T cell help. GC B cells take on a dendritic morphology that may facilitate antigen encounter and affinity discrimination. GCs give rise to more SLPCs, to Bmems, and to long-lived plasma cells (LLPCs).

Ενεργοποίηση Β λεμφοκυττάρων

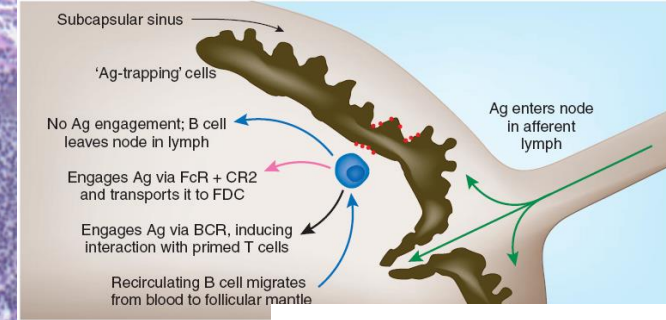
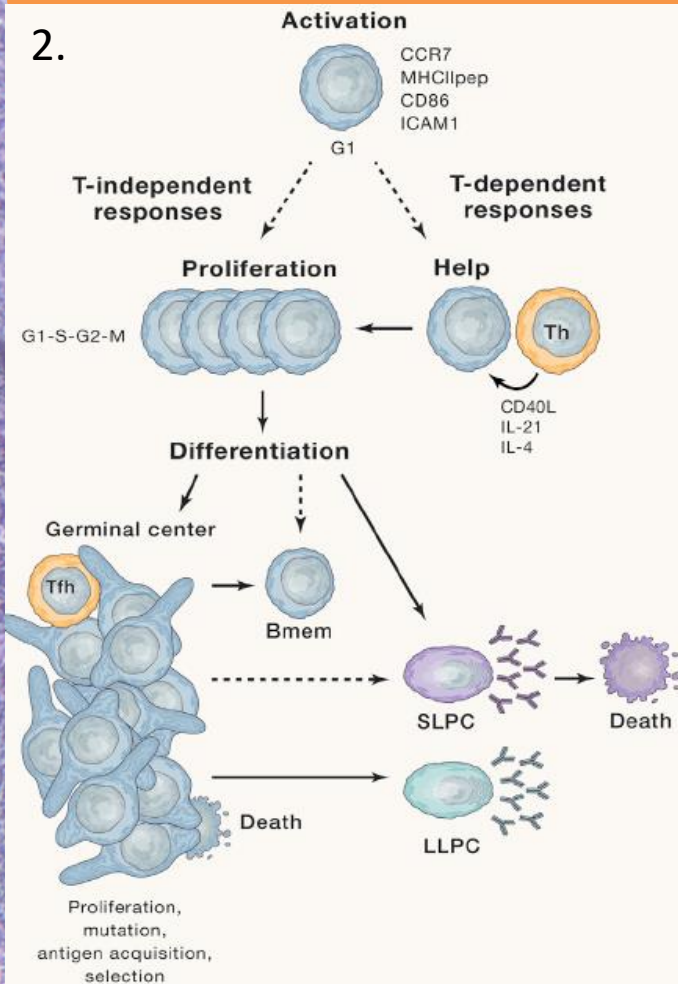

Διαλυτά αντιγόνα

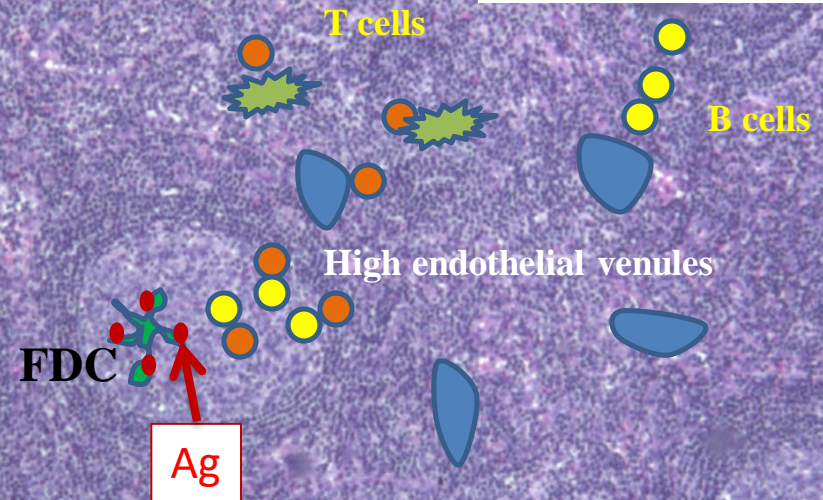

Circulating antigen-specific B cells (blue) that are as rare as 1 in 10^4 to 1 in 10^6 enter and survey an antigen-draining lymph node (LN). A B cell encounters an opsonized (complement coated) antigen displayed on a follicular dendritic cell (FDC) process and receives B cell receptor (BCR) and complement receptor-2 (CR2) signals. Activation involves upregulation of surface molecules, antigen internalization processing and (in the case of protein-containing antigens) presentation as MHC class II peptide (MHCIIpep) complexes, and entry into G1 of cell cycle. If the antigen engages multiple BCRs and/or coreceptors on the B cell, a T-independent (TI) proliferative response ensues. Lower valency protein-containing antigens drive T-dependent (TD) responses, where the B cell depends on signals from helper T cells to undergo proliferation. The proliferative phase is followed by differentiation into short-lived plasma cells (SLPCs), germinal center (GC) B cells, and/or memory B cells (Bmem). The relative differentiation to these distinct states varies and depends on the integration of signals received by the B cell including via the BCR, co-receptors, and T cell help. GC B cells take on a dendritic morphology that may facilitate antigen encounter and affinity discrimination. GCs give rise to more SLPCs, to Bmems, and to long-lived plasma cells (LLPCs).

Ενεργοποίηση Β λεμφοκυττάρων

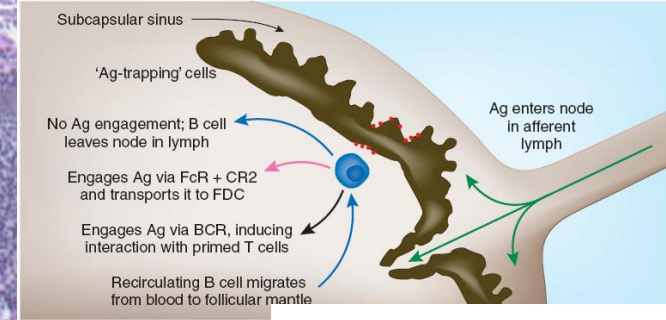
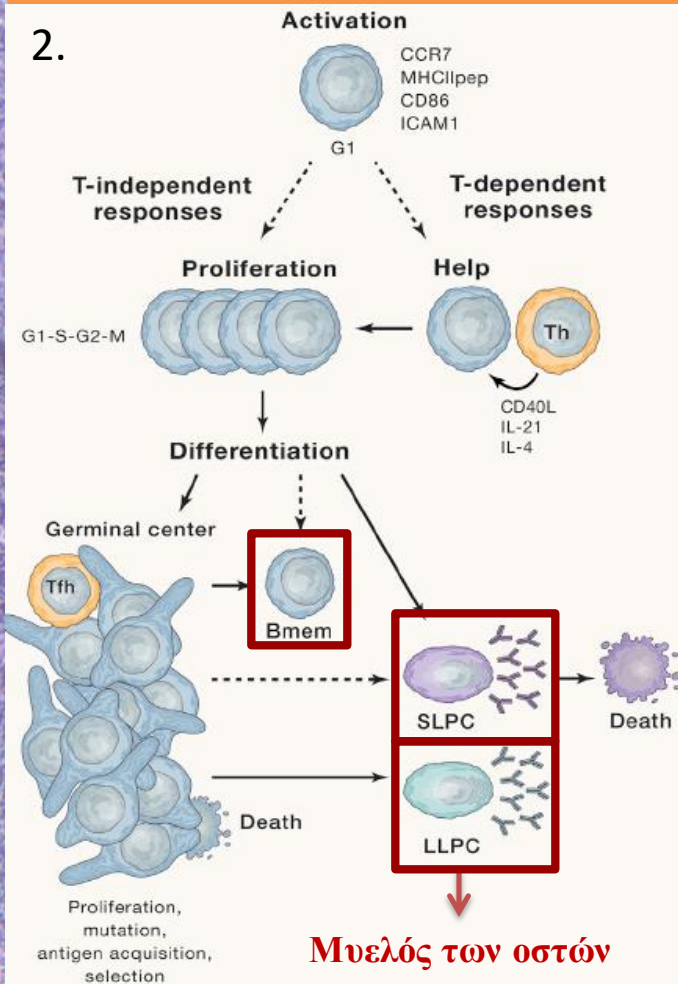

Διαλυτά αντιγόνα

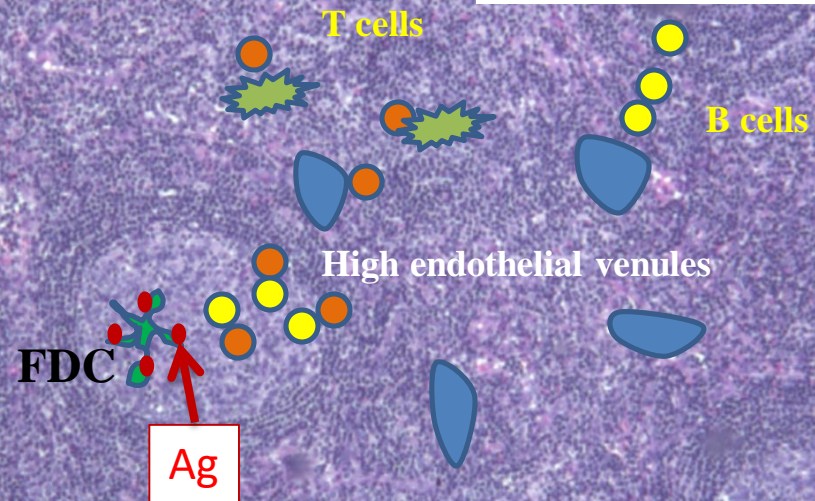

Circulating antigen-specific B cells (blue) that are as rare as 1 in 10^4 to 1 in 10^6 enter and survey an antigen-draining lymph node (LN). A B cell encounters an opsonized (complement coated) antigen displayed on a follicular dendritic cell (FDC) process and receives B cell receptor (BCR) and complement receptor-2 (CR2) signals. Activation involves upregulation of surface molecules, antigen internalization processing and (in the case of protein-containing antigens) presentation as MHC class II peptide (MHCII_{pep}) complexes, and entry into G1 of cell cycle. If the antigen engages multiple BCRs and/or coreceptors on the B cell, a T-independent (TI) proliferative response ensues. Lower valency protein-containing antigens drive T-dependent (TD) responses, where the B cell depends on signals from helper T cells to undergo proliferation. The proliferative phase is followed by differentiation into short-lived plasma cells (SLPCs), germinal center (GC) B cells, and/or memory B cells (Bmem). The relative differentiation to these distinct states varies and depends on the integration of signals received by the B cell including via the BCR, co-receptors, and T cell help. GC B cells take on a dendritic morphology that may facilitate antigen encounter and affinity discrimination. GCs give rise to more SLPCs, to Bmems, and to long-lived plasma cells (LLPCs).

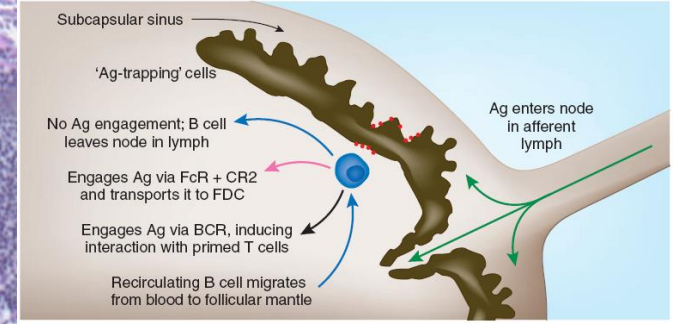
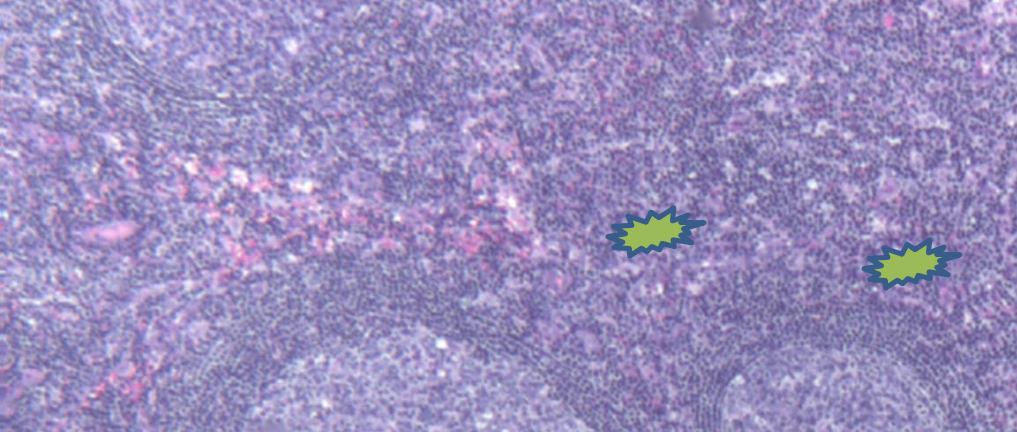

Ενεργοποίηση Β λεμφοκυττάρων

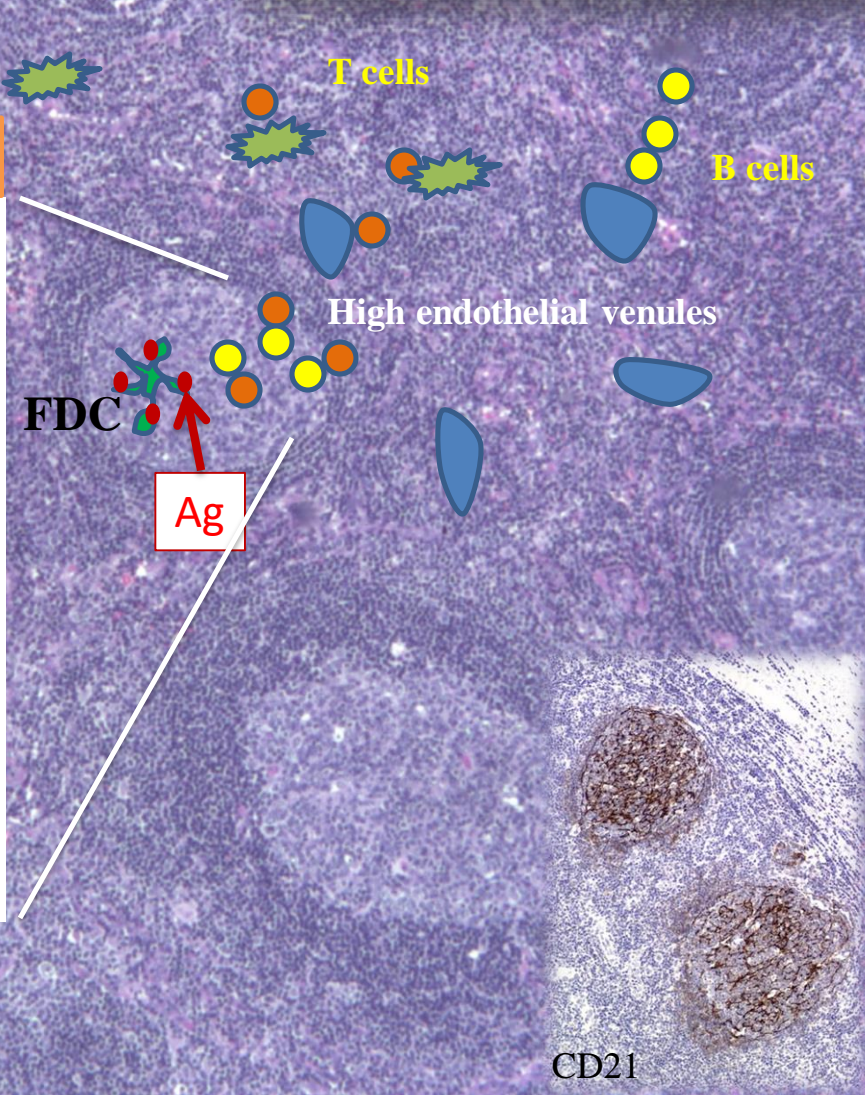
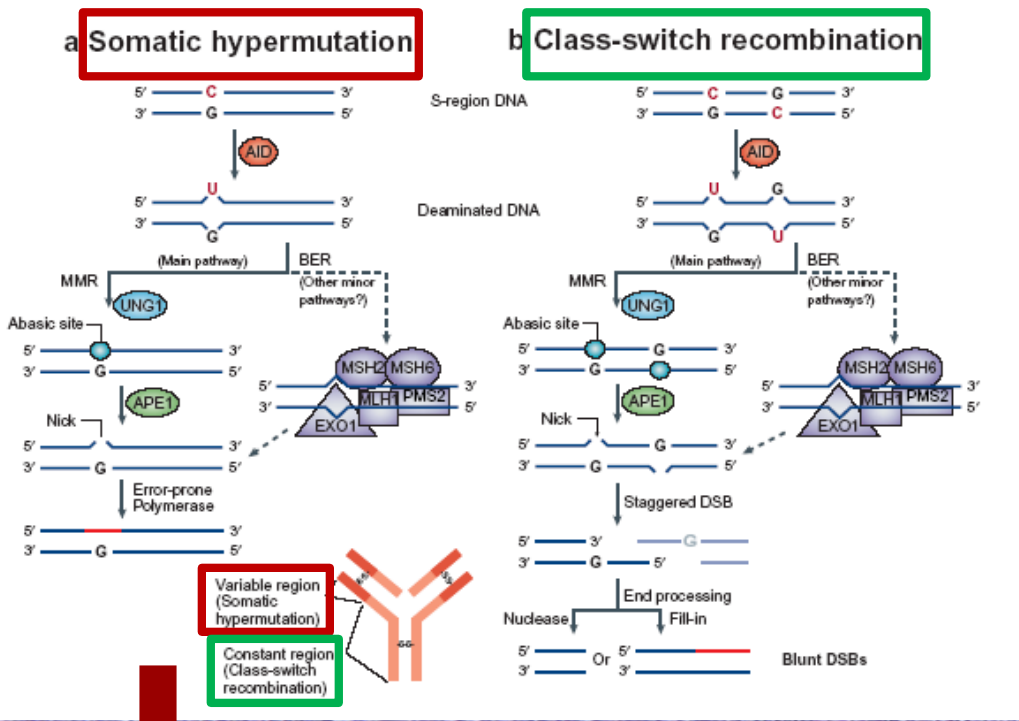

Βελτίωση της χημικής συγγένειας της ανοσοσφαιρίνης προς το αντιγόνο

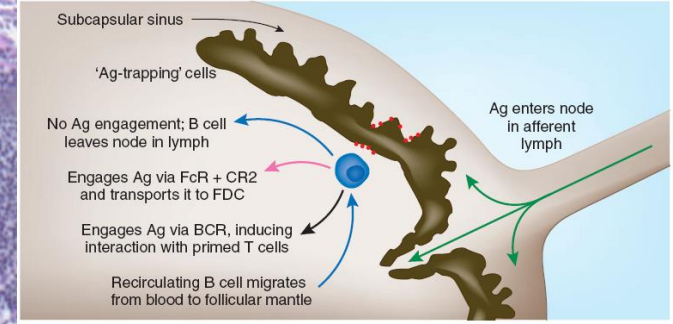

Ενεργοποίηση Β λεμφοκυττάρων

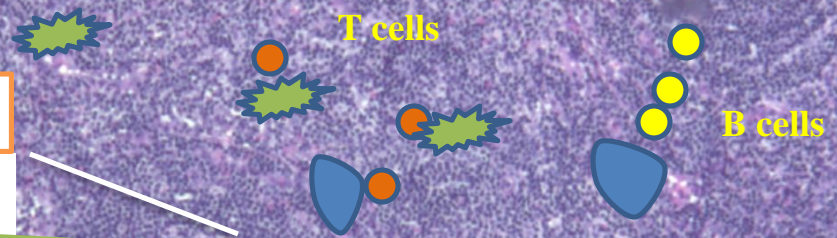

a Somatic hypermutation

b Class-switch recombination

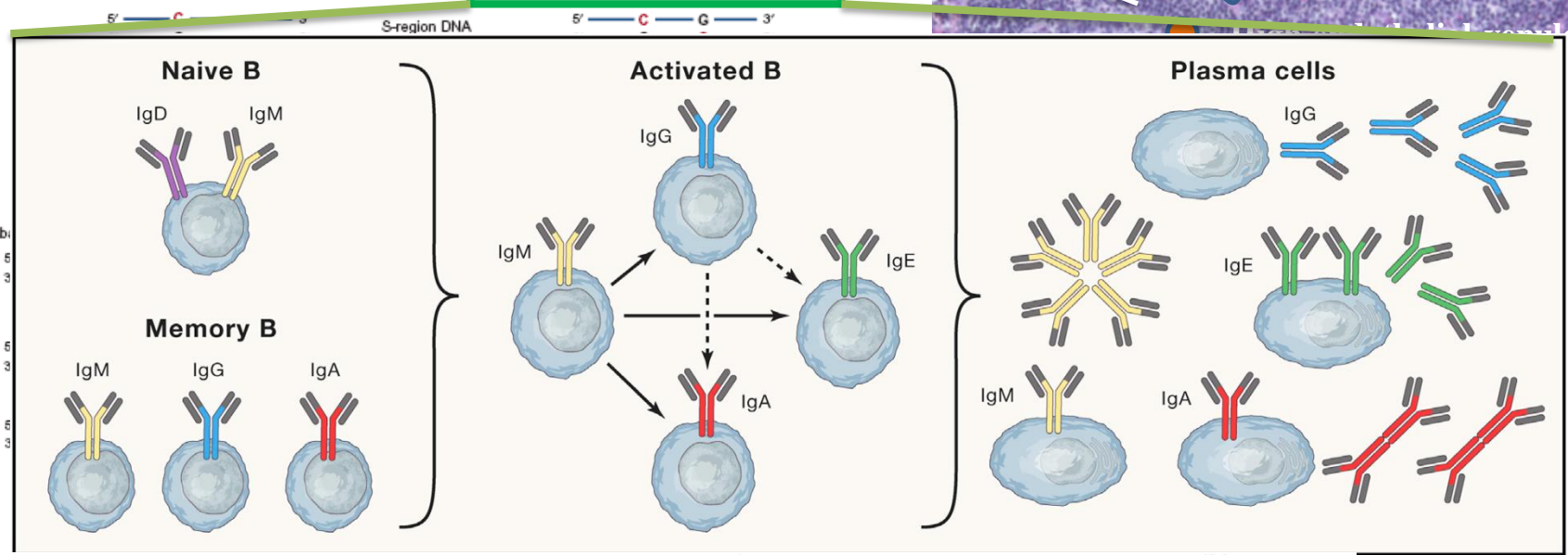

Upon receiving appropriate activation signals, B cells undergo a DNA rearrangement of their Ig Hc gene leading to class switch recombination (CSR, also known as isotype switching). In this process, DNA encoding the constant region of the antibody is replaced with a downstream gene sequence to encode a different isotype. Naive B cells express IgD and/or IgM, and CSR leads to the expression of IgG, IgE, or IgA isotypes. CSR may occur directly (e.g., from IgM and IgD to IgE), or sequentially (e.g., from IgM and IgD to IgG to IgE). Memory B cells may also undergo CSR upon re-activation (e.g., from IgG to IgE). Once cells differentiate into PCs, CSR is extinguished. There are thus multiple paths giving rise to PCs expressing particular antibody isotypes. As well as secreting antibody, IgM, IgA, and IgE PCs retain membrane forms of the antibody.

11/02/2

Αλλαγή της λειτουργίας του Ab

CD21

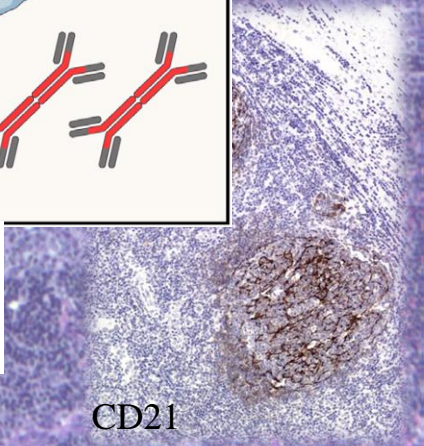

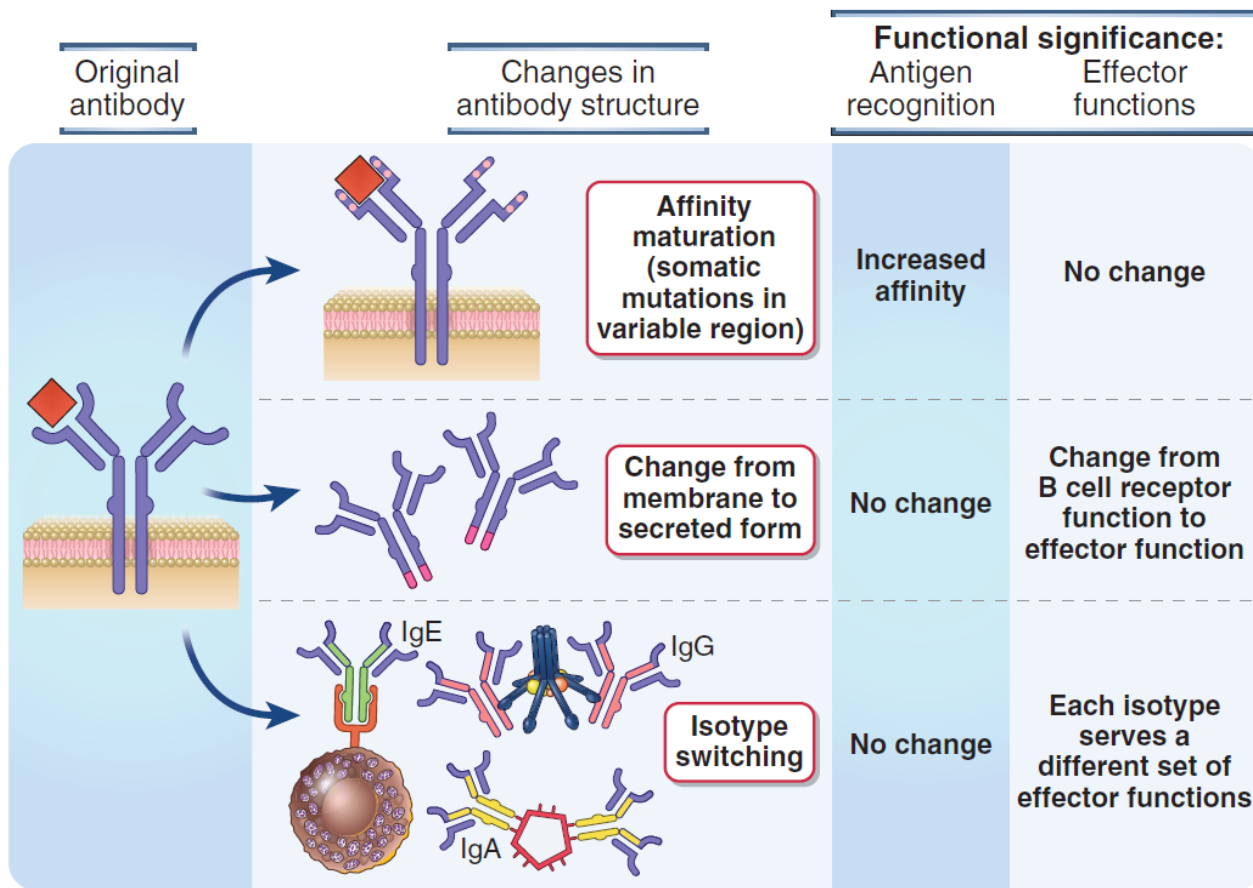
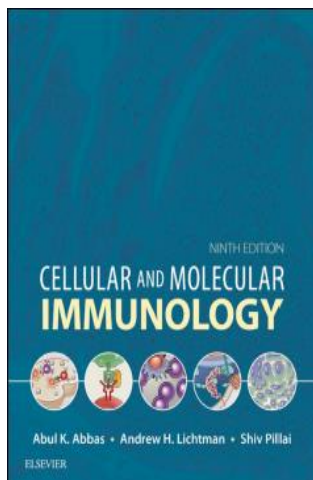
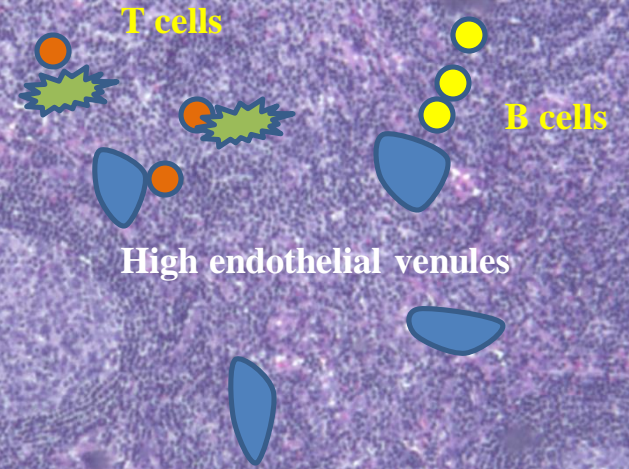
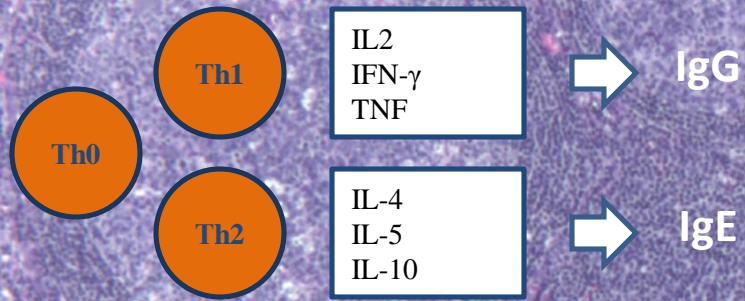
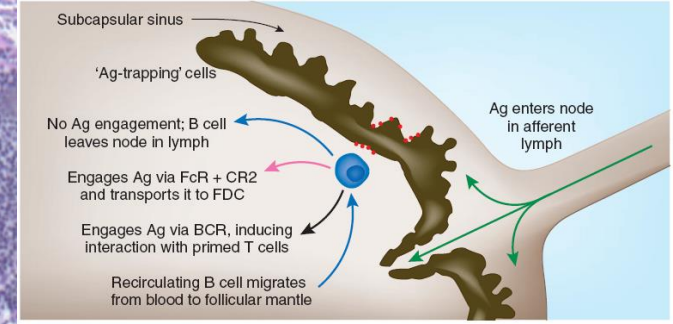
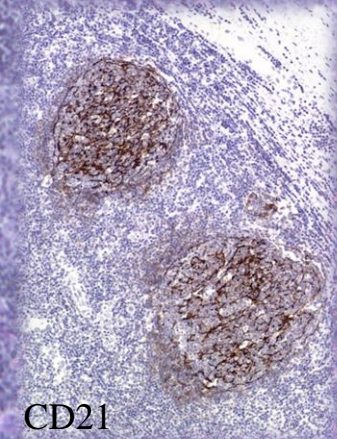

FIGURE 5.16 Changes in antibody structure during humoral immune responses. The illustration depicts the changes in the structure of antibodies that may be produced by the progeny of activated B cells (one clone) and the related changes in function. During affinity maturation, mutations in the V region (indicated by yellow dots) lead to changes in fine specificity without changes in C region–dependent effector functions. Activated B cells may shift production from largely membrane-bound antibodies containing transmembrane and cytoplasmic regions to secreted antibodies. Secreted antibodies may or may not show V gene mutations (i.e., secretion of antibodies occurs before and after affinity maturation). In isotype switching, the C regions change (indicated by color change from purple to green, yellow, or pink) without changes in the antigen-binding V region. Isotype switching is seen in membrane-bound and secreted antibodies. We will discuss the molecular basis for these changes in [Chapter 12](#).





Class-switch recombination=
μεταστροφή της τάξης των ανοσοσφαιρινών



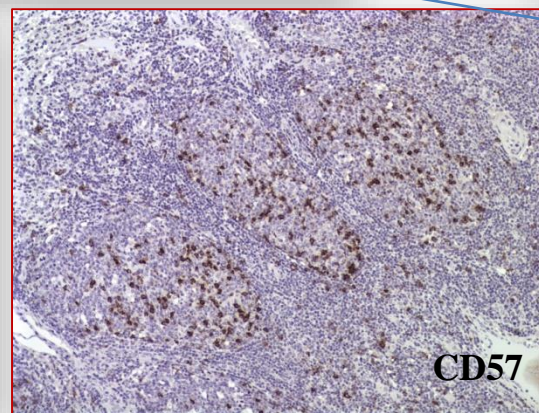
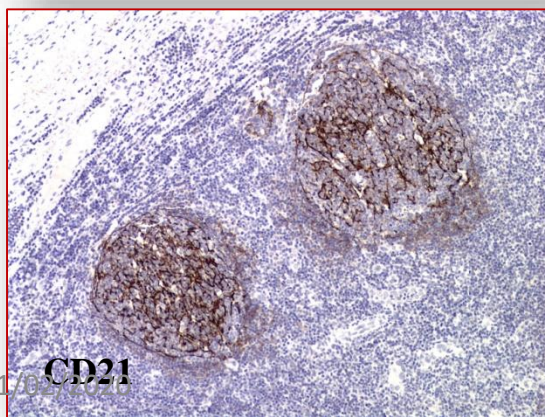
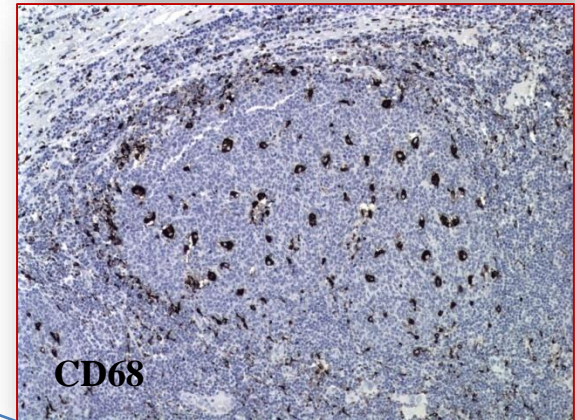
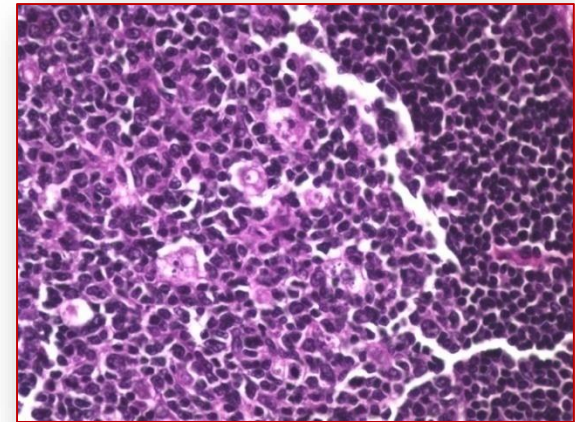
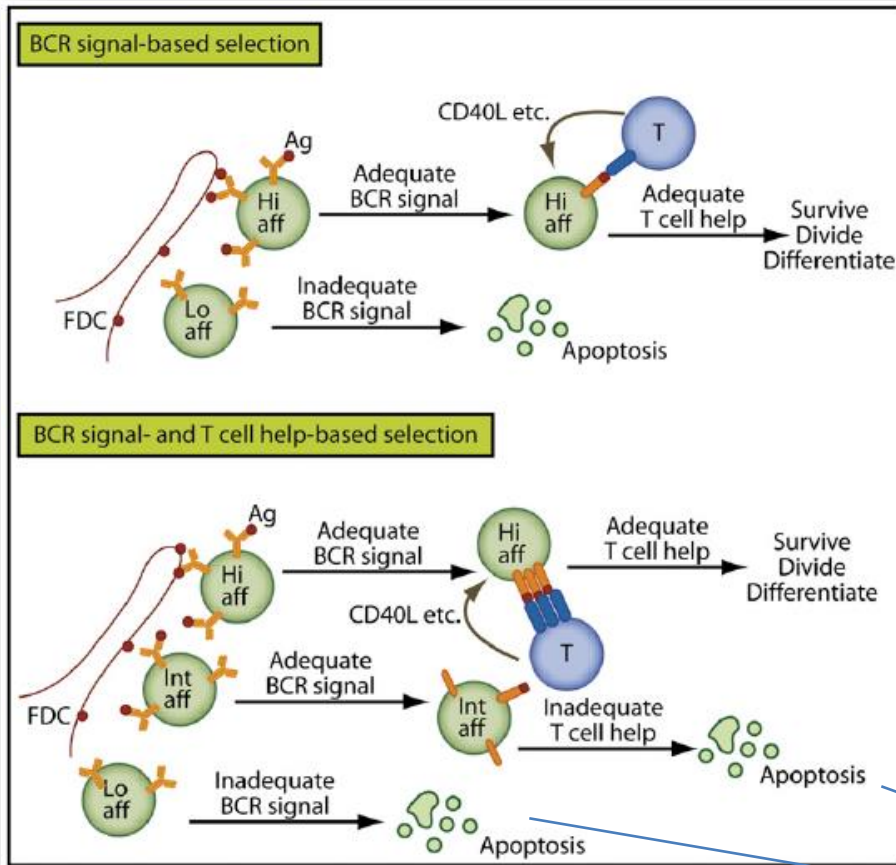

**Φαγοκυττάρωση των
αποπτωτικών σωματιών
από μακροφάγα**



**Εικόνα δικήν έναστρου ουρανού
Starry sky**



B cell lymphomas (~95%)

T cell lymphomas (~5%)

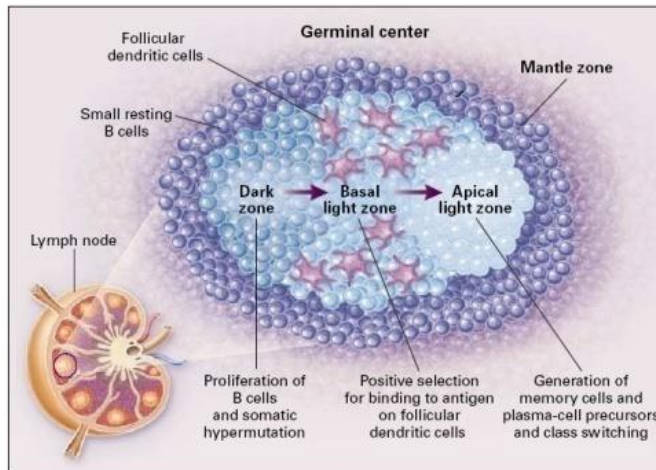

Lymphoid tissue fibrosis is associated with impaired vaccine responses

Cissy Kityo,¹ Krystelle Nganou Makamdop,² Meghan Rothenberger,³ Jeffrey G. Chipman,³ Torfi Hoskuldsson,³ Gregory J. Beilman,³ Bartosz Grzywacz,³ Peter Mugenyi,¹ Francis Ssali,¹ Rama S. Akondy,⁴ Jodi Anderson,³ Thomas E. Schmidt,³ Thomas Reimann,³ Samuel P. Callisto,³ Jordan Schoepfoerster,³ Jared Schuster,³ Proscovia Muloma,¹ Patrick Ssengendo,¹ Eirini Moysi,² Constantinos Petrovias,² Ray Lanciotti,⁵ Lin Zhang,³ Maria T. Arévalo,⁶ Benigno Rodriguez,⁷ Ted M. Ross,⁶ Lydie Trautmann,^{8,9} Rafick-Pierre Sekaly,⁷ Michael M. Lederman,⁷ Richard A. Koup,¹⁰ Rafi Ahmed,⁴ Cavan Reilly,³ Daniel C. Douek,² and Timothy W. Schacker³

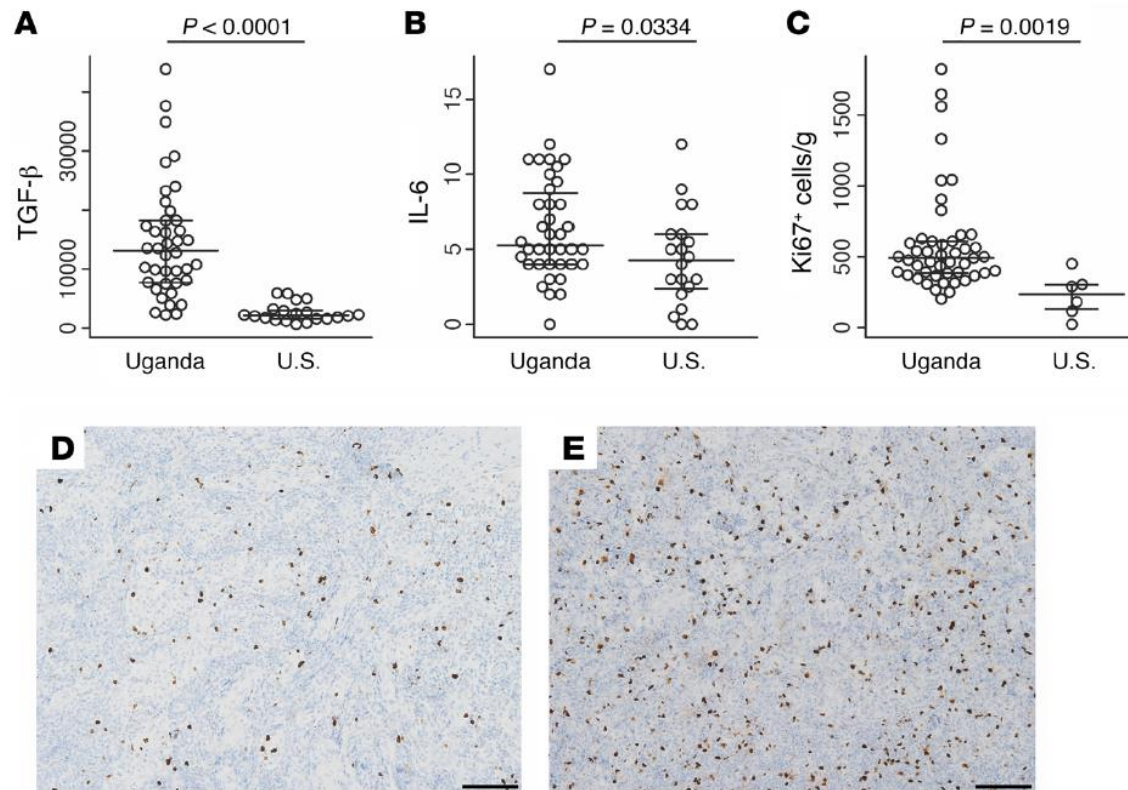

Figure 1. Increased immune activation in HIV⁻ Ugandans. Prevacination plasma samples demonstrated elevated levels of TGF-β (A) and IL-6 (B) in a group from Uganda compared with a group from the U.S. LN sections stained for Ki67 also demonstrated increased immune activation when compared with LN tissues obtained from people in the U.S. (C). Representative sections of LN stained with Ki67 antibodies from an HIV negative person in Minnesota (D) and an HIV negative Ugandan (E) are shown. Scale bars indicate 100 μm and magnification is ×10.

Lymphoid tissue fibrosis is associated with impaired vaccine responses

Cissy Kityo,¹ Krystelle Nganou Makamdop,² Meghan Rothenberger,³ Jeffrey G. Chipman,³ Torfi Hoskuldsson,³ Gregory J. Beilman,³ Bartosz Grzywacz,³ Peter Mugenyi,¹ Francis Ssali,¹ Rama S. Akondy,⁴ Jodi Anderson,³ Thomas E. Schmidt,³ Thomas Reimann,³ Samuel P. Callisto,³ Jordan Schoepfoerster,³ Jared Schuster,³ Proscovia Muloma,¹ Patrick Ssengendo,¹ Eirini Moysi,² Constantinos Petrovias,² Ray Lanciotti,⁵ Lin Zhang,³ Maria T. Arévalo,⁶ Benigno Rodriguez,⁷ Ted M. Ross,⁶ Lydie Trautmann,^{8,9} Rafick-Pierre Sekaly,⁷ Michael M. Lederman,⁷ Richard A. Koup,¹⁰ Rafi Ahmed,⁴ Cavan Reilly,³ Daniel C. Douek,² and Timothy W. Schacker³

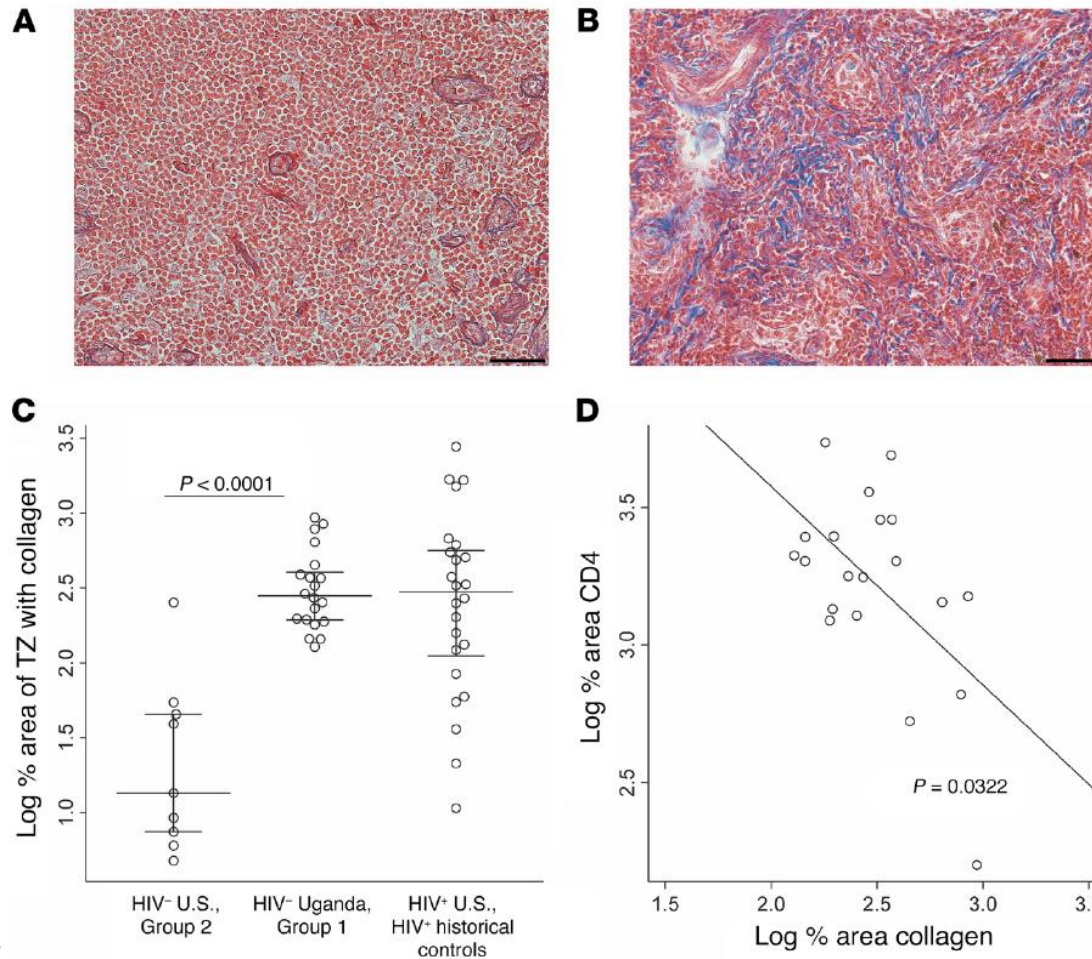

Figure 2. Increased T cell zone fibrosis in people from Uganda. A representative section of LNs stained with trichrome from a person from the U.S. (**A**) was compared with one from a person from Uganda (**B**). There was an increase in the amount of collagen (blue fibers) in the Ugandan sample. LN tissues from the Ugandan participants in Group 1 have a similar amount of collagen as LN tissues from HIV⁻ people from the U.S. in Group 2 (**C**). We see the expected inverse relationship between TZ collagen and the size of the resident CD4⁺ T cell population in the HIV⁻ Ugandans (**D**). Scale bar indicates 50 μ m and magnification is $\times 20$.

Lymphoid tissue fibrosis is associated with impaired vaccine responses

Cissy Kityo,¹ Krystelle Nganou Makamdop,² Meghan Rothenberger,³ Jeffrey G. Chipman,³ Torfi Hoskuldsson,³ Gregory J. Beilman,³ Bartosz Grzywacz,³ Peter Mugenyi,¹ Francis Ssali,¹ Rama S. Akondy,⁴ Jodi Anderson,³ Thomas E. Schmidt,³ Thomas Reimann,³ Samuel P. Callisto,³ Jordan Schoepfoerster,³ Jared Schuster,³ Proscovia Muloma,¹ Patrick Ssengendo,¹ Eirini Moysi,² Constantinos Petrovas,² Ray Lanciotti,⁵ Lin Zhang,³ Maria T. Arévalo,⁶ Benigno Rodriguez,⁷ Ted M. Ross,⁶ Lydie Trautmann,^{8,9} Rafick-Pierre Sekaly,⁷ Michael M. Lederman,⁷ Richard A. Koup,¹⁰ Rafi Ahmed,⁴ Cavan Reilly,³ Daniel C. Douek,² and Timothy W. Schacker³

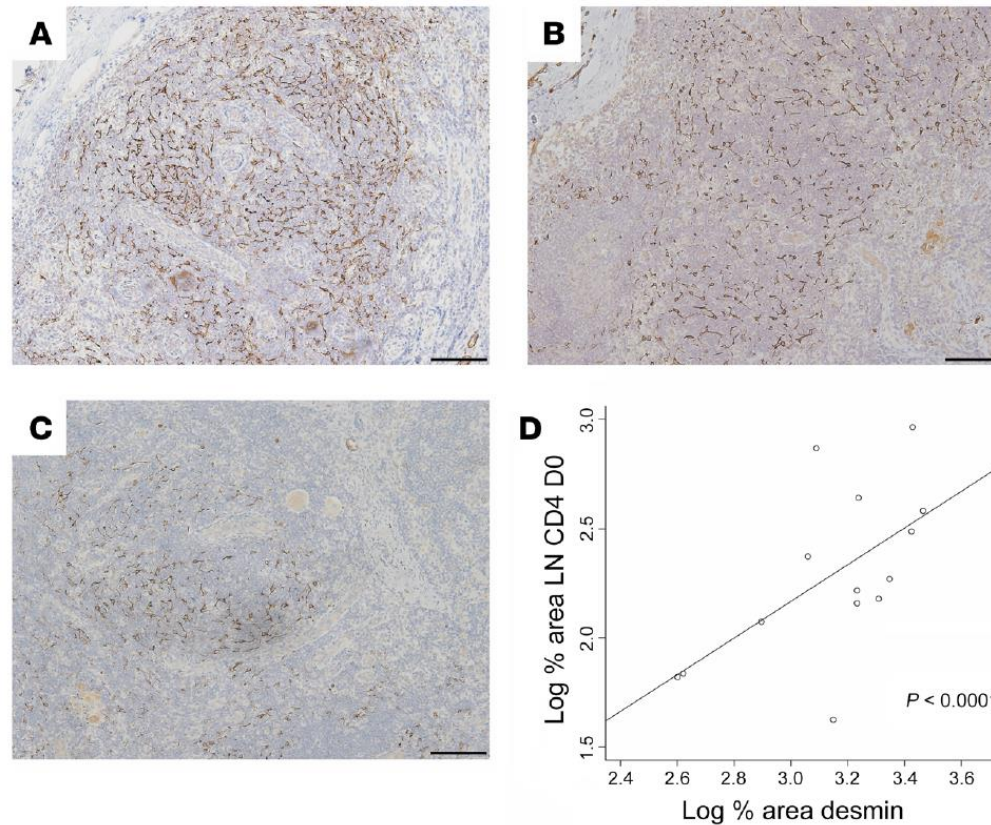

Figure 3. The fibroblastic reticular cell network (FRCn) is depleted in Ugandans. We used QIA to identify TZ desmin in HIV⁺ people in the U.S. (Group 2, **A**) and people from Uganda (Group 1, **B** and **C**) and then used quantitative image analysis to compare the amount of desmin in the section to the size of the CD4⁺ T cell population in the LN (**D**), showing the significant and direct relationship. Scale bar indicates 100 μ m and magnification is $\times 20$.

Lymphoid tissue fibrosis is associated with impaired vaccine responses

Cissy Kityo,¹ Krystelle Nganou Makamdop,² Meghan Rothenberger,³ Jeffrey G. Chipman,³ Torfi Hoskuldsson,³ Gregory J. Beilman,³ Bartosz Grzywacz,³ Peter Mugenyi,¹ Francis Ssali,¹ Rama S. Akondy,⁴ Jodi Anderson,³ Thomas E. Schmidt,³ Thomas Reimann,³ Samuel P. Callisto,³ Jordan Schoepfoerster,³ Jared Schuster,³ Proscovia Muloma,¹ Patrick Ssengendo,¹ Eirini Moysi,² Constantinos Petrovias,² Ray Lanciotti,⁵ Lin Zhang,³ Maria T. Arévalo,⁶ Benigno Rodriguez,⁷ Ted M. Ross,⁶ Lydie Trautmann,^{8,9} Rafick-Pierre Sekaly,⁷ Michael M. Lederman,⁷ Richard A. Koup,¹⁰ Rafi Ahmed,⁴ Cavan Reilly,³ Daniel C. Douek,² and Timothy W. Schacker³

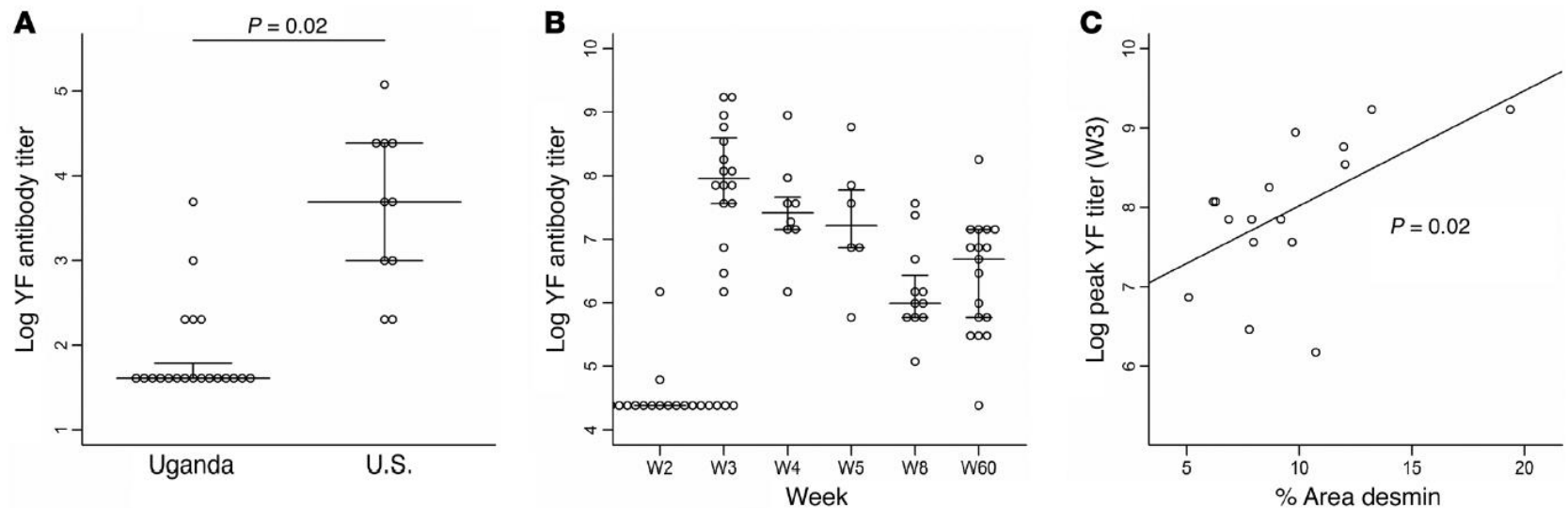

Figure 6. Yellow fever antibody titers. Titers of neutralizing antibody titers from the Ugandan and U.S. groups are compared using a plaque reduction neutralization assay with a starting dilution of 1:20 (**A**), demonstrating that by week 2 all of the U.S. participants had detectable antibodies but only 5 of 20 people from Uganda did. In (**B**) we show the peak titer of the Ugandan participants at day 21 (week 3) and the decline through month 14. In (**C**) we show that measures of desmin in LNs correlate to peak antibody titer.

Vaccine responsiveness

Lymph node fibrosis: a structural barrier to unleashing effective vaccine immunity

Boris Julg and Galit Alter

Ragon Institute of MGH, MIT and Harvard, Cambridge, Massachusetts, USA. Infectious Disease Unit, Massachusetts General Hospital, Boston, Massachusetts, USA.

J Clin Invest. 2018;128(7):2743–2745.

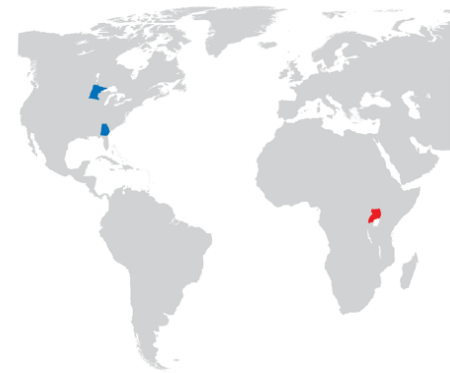
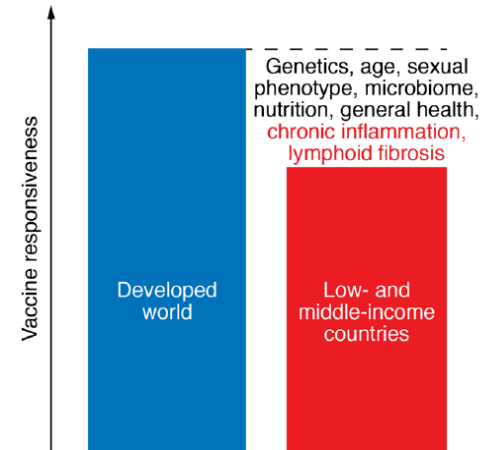
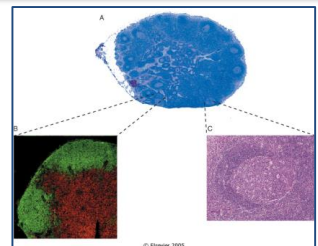
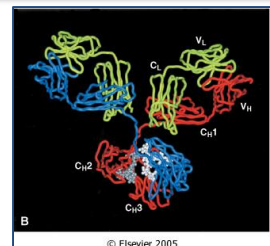
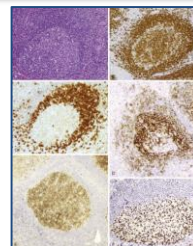
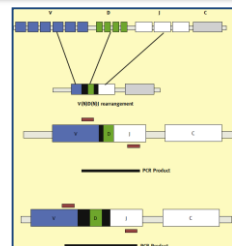
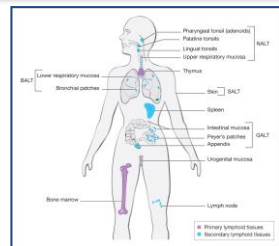
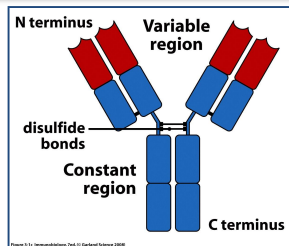
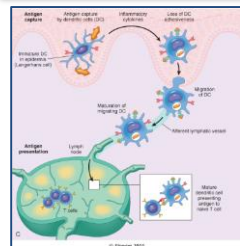

Figure 1. Factors driving lower vaccine responsiveness around the globe. The cartoon bar graph depicts the observed differences in vaccine responsiveness around the globe, and highlights factors that have been associated with vaccine immunogenicity. Factors listed in black have been previously published. Factors listed in red represent the findings in the manuscript by Kityo et al., which evaluated differences in vaccine response in subjects from the U.S. (Minnesota and Georgia, blue) and subjects from Uganda (red).



ΑΝΤΙΓΟΝΑ ΚΑΙ ΑΝΤΙΓΟΝΟΠΑΡΟΥΣΙΑΣΗ

Περικλής Γ. Φούκας
 Β' Εργαστήριο Παθολογικής Ανατομικής
 Ιατρικής Σχολής, ΕΚΠΑ
 Π.Γ.Ν. Αττικόν

ΕΥΧΑΡΙΣΤΩ